

DIVISION 1 - GENERAL REQUIREMENTS

SECTION 01010 - SUMMARY OF WORK

PART 1 - GENERAL

1.01 SCOPE:

Work Included:

- A. Remove existing low-slope roofing systems, walk ways, base flashings, patches, repairs, and insulation down to plywood deck at locations indicated on drawings and dispose of offsite.
- B. Removal of existing sheet metal flashing elements where indicated on drawings or where required to remove existing roofing and to install specified roofing system. Dispose of or store flashings for reinstallation as indicated on project drawings.
- C. Replace all damaged or defective plywood panels as directed by CUSD representative or its consultant. The Base Bid shall include labor and material to replace up to ten (10) damaged or defective (4' x 8' CDX) plywood roof panels of equal thickness as existing. Contractor shall provide unit cost for replacement of additional panels as directed by CUSD representative or Provost and Pritchard representative.
- D. Contractor to provide Unit Cost for replacement of one (1) damaged or defective (4' x 8') plywood roof panel of equal thickness as existing. Cost to include all labor and material to remove one (1) existing panel and install replacement material of equal size and thickness. At completion of project, contractor shall credit CUSD for all unused labor and material for replacement or plywood in the event less than specified is replaced. Credit shall be based on Unit Cost per panel as included on Bid Form (Section 00400).
- E. Install mechanically fastened 80 mil PVC thermoplastic membrane roofing system over layer of ¼" gypsum coverboard as indicated on drawings. Install tapered insulation at the leading edge of all curbs larger than thirty-six (36) inches in width that are horizontal to the roof slope. Use of only manufacturer approved prefabricated or field fabricated membrane accessories are permitted on site. Any material found to deviate from this will be removed and replaced at the contractor's expense. Work is defined as including all material, labor, equipment, and services necessary to complete all work shown on the Drawings and/or as called for in the Specifications.
- F. All membrane terminations are to meet manufacturer requirements including but not limited to, all vertical base flashings, all roof and wall penetrations, mansard leg flashing, drains, vents, heat stacks, etc.
- G. Remove existing 2-piece counter flashings and store for reinstallation after the new roof system is complete as indicated on drawings.
- H. (MPR) Remove existing coping and save for reinstallation. Terminate membrane up and over parapet wall, nail membrane on outer edge of nailer 12" o.c.. Reinstall stored coping as originally installed, treat coping joints and fasteners with sealant and paint. (owner to chose color)
- I. (Snack Bar) Remove existing coping and replace with new standing seam 24g prefinished coping. Install waterproof membrane or clad from shingle roof onto parapet nailer and terminate vertical flashings as indicated above prior to installing new coping.
- J. Incorporate existing mansard support sleepers into new roofing system per manufacturer requirements. Remove and Reinstall metal counter flashings with matching fasteners as indicated on drawings.

- K. Incorporate new PVC roof system into existing drain bowls per manufacturer requirements. Replace drain ring hardware with new stainless steel hardware correctly sized. Inspect drains for damage and report any damaged drains to CUSD representative or its consultant.
- L. Terminate vertical base flashings at shingle flashed wall by removing shingles as needed to terminate the vertical flashing a minimum of 8" above roof deck. Terminate vertical flashing with butyl tape, termination bar, and sealant per manufacturer requirements and reinstall removed shingles or replace with new in like kind. Shingles to flash membrane termination a minimum of 4 inches.
- M. Install new conduit blocking as indicated on drawings.
- N. All materials to be stored and saved for reinstallation are to be secured on site.
- O. Install new PVC walk pad at all roof hatches and door openings.
- P. Refer to drawings and technical specifications for additional information concerning scope of project.
- Q. Removal and reinstallation of through wall HVAC ducting to properly roof in through wall penetrations is required to be done by a sub-contractor who possess a valid C-20 contractors license.
- R. Scope of Contract:

Excepting as otherwise expressly provided herein, the Contractor shall furnish all plant, labor, materials, tools, appliances, access means, equipment, services, fuel and transportation required to complete the general construction of the roof replacement with these specifications and the drawings. The contract will include but shall not be limited to, the principal items of work denoted by the titles of the specifications listed in the index. The work of the contractor shall be made complete and finished in a workmanlike manner in all parts and respects. Work and materials indicated on the drawings or expressly called for in the specifications, but which are manifestly necessary for the proper, full and faithful performance of the work in accordance with the true intent and meaning of the work and contract documents, shall be provided and incorporated in the work by and at the expense of the Contractor and to the same effect as if both indicated on the drawings and hereinafter specified.

- S. Specifications:

All work indicated on the drawings shall conform to all requirements of the terms and conditions, safety and fire regulations, the general conditions, the specifications and to all addenda and instruction that may be issued subsequently by Clovis Unified School District to supplement, modify, or to interpret the work indicated on the drawings. Changes to be by written Change Orders or addenda. All Change Orders shall be signed by representative of Clovis Unified School District, and the Contractor.

- T. Drawings:

All work shall conform to all requirements of the drawings and to such supplemental detail drawings as may be issued subsequently by Clovis Unified School District to further delineate and explain the work of the contractor.

- U.. Mandatory Pre-Bid Site Visit:

A mandatory pre-bid conference shall be required for this contract at the time(s) and date(s) as determined by Clovis Unified School District. Failure to attend and sign-in at the pre-bid conference will result in the rejection of the bid.

PART 2 - SCHEDULES

2.01 CODES:

- A. All materials and workmanship must conform to the current standards and the requirements of the following codes and regulations. A copy of these codes shall be at the job site at all times.
1. CCR-T8 California Code of Regulations, Title 8 - Industrial Safety.
 2. CCR-T19 California Code of Regulations, Title 19 - Public Safety.
 3. CCR-T24. California Code of Regulations, Title 24, Part 1 Administrative Regulations, DSA-SSS.
 4. CBC California Building Code, California Code of Regulations, Title 24, Part 2, CCR-T24, Current Edition.
 5. CEC California Electrical Code, California Code of Regulations, Title 24, Part 3.
 6. CMC California Mechanical Code, California Code of Regulations, Title 24, Part 4.
 7. CPC California Plumbing Code, California Code of Regulations, Title 24, Part 5.
 8. CFC California Fire Code (based on the National Fire Code by NFPA)

2.02 CONSTRUCTION SCHEDULE:

- A. Work on the referenced project is authorized to proceed upon written Notice of Award, contingent upon acceptance and approval of required documentation referenced in these specifications and Clovis Unified School District "General Conditions".
- B. Contractor shall furnish the Clovis Unified School District with a copy of construction schedule showing relative dates for completion of project. It shall also cooperate with Clovis Unified School District in minimizing disruption of the building occupants.

2.03 CONSTRUCTION COORDINATION:

Students, faculty, employees of the facility and private citizens may be within the specified buildings or on the school grounds during the roof construction project. Contractor shall plan and execute their work with an awareness of the presence and location of building occupants and those occupying the building grounds.

PART 3 - EXECUTION

3.01 BUILDING PROTECTION FROM ELEMENTS:

The Contractor shall provide for protection from rain or other moisture through the roof plane at all times during this contract. Any damage resulting from such happening shall be the full responsibility of the Contractor. Contractor shall repair any and all damage to satisfaction of Clovis Unified School District resulting from or associated with moisture intrusion associated with the work performed under the contract.

PART 4 - CLEANING UP:

4.01 CLEAN UP:

Contractor shall leave premises clean, neat and orderly on a daily basis.

All trash, wrappers, debris, nails, screws, metal shards and other items associated with the work under the contract shall be removed from the roofs as well as the school property to the satisfaction of CUSD.

PART 5 - PROJECT CLOSE OUT:

5.01 NOTICE OF COMPLETION:

All work shall be coordinated with Clovis Unified School District and shall be conducted during hours as stipulated. This work shall be coordinated with Clovis Unified School District prior to commencing work operations. Work shall commence within 10 days of Notice to Proceed and shall be completed within 60 calendar days. Liquidated damages shall accrue for each calendar day after 60 calendar days and the amount of \$1,000.00 (or amount indicated in CUSD General Conditions section) shall be deducted from monies owed Contractor under the Agreement for each day after the specified contract period. If this information conflicts with Owner's General and Supplementary Conditions, Owners requirements take precedence of specs.

5.02 GUARANTEES:

The Contractor shall deliver to the Clovis Unified School District all guarantees and/or warranties as called for in other divisions of the specifications and one copy (or more as required) of all such guarantees to Clovis Unified School District's Representative.

END OF SECTION 01010

DIVISION 1 - GENERAL REQUIREMENTS

SECTION 01300 - SUBMITTALS

PART 1 - GENERAL

1.01 GENERAL:

- A. The Contractor shall check, verify, and be responsible for all field measurements.
- B. All submittals shall be approved before any work will commence.
- C. Clovis Unified School District's Representative will make any corrections with reasonable promptness and return the submittal to the Contractor within a time frame required to complete the work within the designated contract period.
- D. Clovis Unified School District's Representative review of submittals and shop drawings shall not relieve the Contractor of responsibility for deviations from the drawings or specifications, unless he has, in writing, called Clovis Unified School District's Representative's attention to such deviations at the time of original submission, and secured written approval.

1.02 CONTRACT SUBMITTALS:

- A. Material Information: Submit material information requested in each section of specifications.
- B. Samples of proposed roofing materials, insulation, fasteners, and paint colors
- C. Manufacturer's Data: Submit manufacturer literature and proof of manufacturer notifications with respect to warranty as required in Section 07542 (PCV Thermoplastic Roofing System).
- D. Safety Data Sheets (SDS) for all products used which are classified as hazardous by State and Federal Governments.
- E. Any other documents required by the Clovis Unified School District or its Consultant.

1.03 PRE-CONSTRUCTION SUBMITTALS:

- A. Construction Schedule: The Contractor shall submit a proposed construction schedule.

1.04 PROJECT CLOSE OUT SUBMITTALS:

- A. Contractor's Workmanship Guarantee (on letterhead)
- B. Manufacturer's Roof System Guarantee.
- C. Additional documents as required by Clovis Unified School District

END OF SECTION 01300

DIVISION 1 - GENERAL REQUIREMENTS

SECTION 01500 - TEMPORARY FACILITIES

PART 1 - GENERAL

1.01 RELATED DOCUMENTS:

Drawings and general provisions of the Contract, including General and Supplementary Conditions and other Division-1 Specification Sections, apply to this Section.

1.02 SUMMARY:

This Section specifies requirements for temporary services and facilities, including utilities, construction and support facilities, security, and protection.

A. Temporary construction and support facilities required include but are not limited to:

1. Temporary enclosures.
2. Hoists.
3. Temporary Project identification signs and bulletin boards.
4. Waste disposal services.
5. Construction aids and miscellaneous services and facilities.
6. Portable Restroom Facilities (to be cleaned and serviced weekly).

B. Security and protection facilities required include but are not limited to:

1. Temporary fire protection.
2. Barricades, warning signs, lights.
3. Sidewalk bridge or enclosure fence for the site.
4. Environmental protection.
5. Fall protection

1.03 TEMPORARY FENCING:

Provide and install temporary fencing as required by the Clovis Unified School District or as necessary to protect Contractor's property and equipment. If the fenced area is to be locked during non-occupied hours, Clovis Unified School District shall be provided with a key for the lock or the combination. Fenced areas shall include signage in English and Spanish restricting access.

1.04 FALL PROTECTION

Contractor to provide, install and utilize fall protection as required by Cal/OSHA regulations. Contractor shall retain the services of a fall protection consultant or professional engineer as required to provide fall protection design and calculations to provide code compliant fall protection system.

1.05 SUBMITTALS:

- A. Description of temporary fencing utilized during periods when school site locations are in session.
- B. Copy of fall protection plan signed by safety representative of the contracting firm, licensed safety professional, or professional engineer.

1.06 QUALITY ASSURANCE:

- A. Regulations: Comply with industry standards and applicable laws and regulations if authorities having jurisdiction, including but not limited to:
 - 1. Building Code requirements.
 - 2. Health and safety regulations.
 - 3. Utility company regulations.
 - 4. Police, Fire Department and Rescue Squad rules.
 - 5. Environmental protection regulations.
- B. Standards: Comply with NFPA Code 241, "Building Construction and Demolition Operations", ANSI-A10 Series standards for "Safety Requirements for Construction and Demolition", and NECA Electrical Design Library "Temporary Electrical Facilities."
- C. Inspections: Arrange for authorities having jurisdiction to inspect and test each temporary utility before use. Obtain required certifications and permits.

1.07 PROJECT CONDITIONS:

- A. Temporary Utilities: Prepare a schedule indicating dates for implementation and termination of each temporary utility. At the earliest feasible time, when acceptable to Clovis Unified School District, change over from use of temporary service to use of the permanent service.
- B. Conditions of Use: Keep temporary services and facilities clean and neat in appearance. Operate in a safe and efficient manner. Take necessary fire prevention measures. Do not overload facilities or permit them to interfere with progress. Do not allow hazardous dangerous or unsanitary conditions, or public nuisances to develop or persist on the site.

PART 2 - PRODUCTS

2.01 MATERIALS:

- A. General: Provide new materials; if acceptable to the Clovis Unified School District's Representative, undamaged previously used materials in serviceable condition may be used. Provide materials suitable for the use intended.
- B. Lumber and Plywood: Comply with requirements in Division-6 Section "Rough Carpentry."
- C. For safety barriers, sidewalk bridges and similar uses, provide a minimum of 5/8" thick exterior plywood.

2.02 EQUIPMENT:

- A. General: Provide new equipment. If acceptable to Clovis Unified School District's Representative, undamaged, previously used equipment in serviceable condition may be used. Provide equipment suitable for use intended.
- B. Electrical Outlets: Provide properly configured NEMA polarized outlets to prevent insertion of 110-120 volt plugs into higher voltage outlets. Provide receptacle outlets equipped with ground-fault circuit interrupters, reset button and pilot light, for connection of power tools and equipment.
- C. Electrical Power Cords: Provide grounded extension cords; use "hard-service" cords where exposed to

abrasion and traffic. Provide waterproof connectors to connect separate lengths of electric cords, if single lengths will not reach areas where construction activities are in progress.

- D. Temporary Toilet Units: Provide self-contained single-occupant toilet units of the chemical, aerated recirculation, or combustion type, properly vented and fully enclosed with a glass fiber reinforced polyester shell or similar nonabsorbent material. Place at location approved by Owner.
- E. First Aid Supplies: Comply with governing regulations.
- F. Fire Extinguishers: Provide hand-carried, portable UL-rated, class "A" fire extinguishers for temporary offices and similar spaces. In other locations provide hand-carried, portable, UL-rated, class "ABC" dry chemical extinguishers, or a combination of extinguishers of NFPA recommended classes for the exposures.
- G. Comply with NFPA 10 and 241 for classification, extinguishing agent and size required by location and class of fire exposure.

PART 3 - EXECUTION

3.01 INSTALLATION:

- A. Use qualified personnel for installation of temporary facilities. Locate facilities where they will serve the Project adequately and result in minimum interference with performance of the Work. Relocate and modify facilities as required.
- B. Use Charges: Cost or use charges for temporary facilities are not chargeable to Clovis Unified School District and will not be accepted as a basis of claims for a Change Order.

3.02 TEMPORARY CONSTRUCTION AND SUPPORT FACILITIES INSTALLATION:

- A. Sanitary facilities include temporary toilets, wash facilities and drinking water fixtures. Comply with regulations and health codes for the type, number, location, operation and maintenance of fixtures and facilities. Install where facilities will best serve the Project's needs.
- B. Provide toilet tissue, paper towels, paper cups and similar disposable materials for each facility. Provide covered waste containers for used material.
- C. Temporary Lifts and Hoists: Provide facilities for hoisting materials and employees. Truck cranes and similar devices used for hoisting materials are considered "tools and equipment" and not temporary facilities.
- D. Temporary Signs: Prepare signs to provide directional information to construction personnel and visitors.
- E. Collection and Disposal of Waste: Collect waste from construction areas and elsewhere daily. Comply with requirements of NFPA 241 for removal of combustible waste material and debris. Enforce requirements strictly. Do not hold materials more than 7 days during normal weather or 3 days when the temperature is expected to rise above 80 degrees F. (27 degrees C.) Handle hazardous, dangerous, or unsanitary waste materials separately from other waste by containerizing properly. Dispose of material in a lawful manner.
- F. Provide temporary shade structure for use on roof by Contractor employees as required under Cal/OSHA.

3.03 SECURITY AND PROTECTION FACILITIES INSTALLATION:

- A. Temporary Fire Protection: Until fire protection needs are supplied by permanent facilities, install, and maintain temporary fire protection facilities of the types needed to protect against reasonably predictable and controllable fire losses. Comply with NFPA 10 "Standard for Portable Fire Extinguishers," and NFPA 241 "Standard for Safeguarding Construction, Alterations and Demolition Operations."
- B. Locate fire extinguishers where convenient and effective for their intended purpose, but not less than two fire extinguishers on the roof maintained in the area of stored materials adjacent to the immediate work area.
- C. Store combustible materials in containers in fire-safe locations.
- D. Maintain unobstructed access to fire extinguishers, fire hydrants, temporary fire protection facilities, stairways and other access routes for fighting fires. Prohibit smoking in hazardous fire exposure areas.
- E. Barricades, Warning Signs and Lights: Comply with standards and code requirements for erection of structurally adequate barricades. Paint with appropriate colors, graphics and warning signs to inform personnel and the public of the hazard being protected against. Where appropriate and needed provide lighting, including flashing red or amber lights.
- F. Storage: Where materials and equipment must be stored, and are of value or attractive for theft, provide a secure lockup. Enforce discipline in connection with the installation and release of material to minimize the opportunity for theft and vandalism.
- G. Environmental Protection: Provide protection, operate temporary facilities and conduct construction in ways and by methods that comply with environmental regulations, and minimize the possibility that air, waterways and subsoil might be contaminated or polluted, or that other undesirable effects might result. Avoid use of tools and equipment which produce harmful noise. Restrict use of noise making tools and equipment to hours that will minimize complaints from persons or firms near the site.

3.04 OPERATION, TERMINATION AND REMOVAL:

- A. Supervision: Enforce strict discipline in use of temporary facilities. Limit availability of temporary facilities to essential and intended uses to minimize waste and abuse.
- B. Maintenance: Maintain facilities in good operating condition until removal. Protect from damage by freezing temperatures and similar elements.
- C. Termination and Removal: Unless the Clovis Unified School District's Representative requests that it be maintained longer, remove each temporary facility when the need has ended, or when replaced by authorized use of a permanent facility, or no later than Substantial Completion. Complete or, if necessary, restore permanent construction that may have been delayed because of interference with the temporary facility. Repair damaged Work, clean exposed surfaces and replace construction that cannot be satisfactorily repaired.
- D. Materials and facilities that constitute temporary facilities are property of the Contractor.

END OF SECTION 01500

DIVISION 2 - SITEWORK

SECTION 02050 - DEMOLITION

PART 1 - GENERAL

1.01 DESCRIPTION:

- A. Work Included:
1. Furnish all labor and materials to remove roofing system, insulation, patches, repairs flashings and related components down to structural deck in order to properly install specified roofing system and related components. Remove existing flashings as indicated on the drawings and/or as specified herein, or as required to remove existing roofing and properly install the specified roofing system and related elements.
 2. The work includes, but is not limited to the following:
 - a. Remove existing flashings at locations indicated on drawings and dispose of offsite or save for reinstallation as indicated on drawings.
 - b. Removal of vents and other elements as specified or as required for appropriate for removal of existing roofing and installation of new PVC roofing system, gypsum coverboards, and related flashings. Store elements for reinstallation as indicated on drawings.
 - d. Removal of non-functioning items, service lines, flashings and related components as indicated on drawings or as requested by CUSD representatives.
 - e. Temporarily support roof elements, including condensate, plumbing and electrical lines as required to remove existing roofing system and to properly install the new specified roofing system and related elements. Reinstall new supports as indicated on drawings.
 - i. All miscellaneous demolition required for proper installation of new roof system.
 - j. All roof-top equipment shall remain operational during construction unless permission is given by CUSD to temporarily shut down operation.
- B. The Contractor shall be solely responsible for his methods in regard to demolition, shoring and bracing. This responsibility extends to the preparation of engineered designs and the ultimate performance of all shoring or bracing systems.
- C. The requirements of this Section apply to all demolition work and are additional to the requirements related to the abatement of asbestos containing roofing materials (where required by regulation).

1.02 RELATED WORK DESCRIBED ELSEWHERE:

- A. Section 01010 – Summary of Work
- B. Section 06100 – Rough Carpentry
- C. Section 07542 – PVC Thermoplastic Roofing System

D. Section 07600 – Sheet Metal Work

1.03 CONDITIONS OF PREMISES:

- A. Visit site, accept premises as found. Clovis Unified School District assumes no responsibility for condition of building on site, or continuation in conditions existing at time of proposal invitation or thereafter.
- B. Assume risk regarding damage or loss, whether by reason of fire, theft or other casualty or happening to specified buildings from and after proposal invitation date; no such damage or loss shall relieve Contractor from contract obligations to complete the work.

1.04 SCHEDULE:

- A. All demolition work shall be coordinated with Clovis Unified School District and shall be conducted during hours as stipulated. This work shall be coordinated with Clovis Unified School District prior to commencing work operations.

1.05 REGULATORY REQUIREMENTS

Perform all Work in compliance with all applicable Federal, State, regional and local statutes, laws, regulations, rules, and ordinances.

1.06 DEMOLITION PROCEDURES:

- A. Debris:
 - 1. Materials on the site specified to be removed shall be disposed of by the Contractor (except as specifically reserved for other use or specified to be reused in the work) and any salvage value of such material shall be reflected in the Contractor's bid.
 - 2. Where the word "remove" occurs herein, it shall mean removal from the site unless indicated otherwise.
 - 3. Remove all debris from the roof surface prior to installation of new roofing system.
 - 4. Remove or modify existing vent pipe flashings, sheet metal jacks, counterflashing's and similar items where indicated or as required to install new roofing system.
 - 5. Remove, as it accumulates, debris resulting from demolition operations, except as otherwise specified. Do not store or permit debris to accumulate on site. No overnight stockpiling of debris on the roof shall be permitted. If Contractor fails to remove excess debris promptly, Clovis Unified School District reserves the right to cause same to be removed at Contractor's expense.
 - 6. Contractor shall clean up the building roofs and be responsible for keeping the building roofs and surrounding area in a neat and orderly condition.
 - 7. Clean the roof deck surfaces of all loose material and other impediments that will be detrimental to the application of the new roofing materials.
 - 8. Contractor shall notify Clovis Unified School District of any defective conditions discovered immediately so that corrective measures may be taken.
- B. Maintaining Traffic:

1. Do not close or obstruct access ways utilized for building and facility operations, nor store material in passageways without permission of Clovis Unified School District. Clovis Unified School District shall be notified concerning how long an area will be inaccessible to employees, and the general public.
 2. Conduct operations with no interference with normal building operation.
- C. Protection of Structures and Property:
1. Execute demolition work to insure adjacent property and buildings against damages which might occur from falling debris or other cause. Do not interfere with use of adjacent buildings, maintain free, safe passage to and from same.
 2. Repair damage done to Clovis Unified School District's property of any other person or persons on or off the premises by reason of required work.
 3. Take necessary safety precautions to guard against any accidents to either the occupants of the building or those of the Contractor.
 4. Protect the contents in building from dirt, debris, and asphalt during demolition.
 5. Take necessary steps to protect building occupant vehicles from damage due to actions of the Contractor. Contractor shall be responsible for all damage to vehicles, which is the result of his actions.

1.07 UNFORESEEN CONDITIONS

- A. Should unforeseen conditions be encountered that affect the execution of the Work, investigate the existing conditions fully and submit a detailed written report to Clovis Unified School District. While awaiting Clovis Unified School District's response, reschedule operations as necessary to avoid delaying the completion of the project.

1.08 CLEANING

- A. Upon completing work, remove tools, materials, branch apparatus, temporary toilets and rubbish of every kind.
- B. Leave premises clean, neat and orderly on a daily basis.

END OF SECTION 02050

DIVISION 6 - WOOD

SECTION 06100 - ROUGH CARPENTRY

PART 1 - GENERAL

1.01 DESCRIPTION:

- A. Work Included:
1. Supply and install all lumber and plywood as shown on the drawings and/or as specified herein and as required.
 2. The Base Bid for Liberty Elementary includes all labor and material to replace up to ten (10) 4' x 8' sheets of CDX plywood roof sheathing. Contractor shall also provide a unit price for replacement per 4' x 8' sheet of CDX plywood roof sheathing as directed by CUSD or Provost and Pritchard representative. Unit price includes labor and material. At completion of project, successful contractor shall credit CUSD for all labor and material for replacement of plywood sheathing in the Base Bid which are not replaced. Credit shall be based on Unit Cost per sheet. All replacement panels are to match existing plywood deck thickness.
 3. Install new wood nailers as shown or indicated on drawings. New nailers shall be fully incorporated into the new roofing system.
 4. All wood items shall be secured with non-corrosive nails or screws of appropriate length and diameter to secure component in place per applicable building code requirements. Unless indicated otherwise, fasteners shall be spaced at 6-inches on center in a staggered pattern. Lengths will vary depending on thickness of deck and component to which they are attached. Contractor shall be responsible for confirming lengths of fasteners to prevent exposure from below. Submit samples of fasteners as part of submittal.
 5. All miscellaneous carpentry and lumber shown on the Drawings or called for in the Specifications.
- B. The work required under this section consists of all roofing related items necessary and required to complete the work as indicated in the Contract Documents.
- C. The Contractor shall comply with the requirements of OSHA's Hazard Communications Standard including hazardous materials and employee training.
- D. Provide all material, labor, equipment and services necessary to complete all carpentry, accessories and other related items necessary to complete the Project as indicated by the Construction Documents unless specifically excluded.

1.02 RELATED WORK SPECIFIED ELSEWHERE:

- A. Section 01010 Summary of Work
- B. Section 07220 Rigid Insulation & Gypsum Cover Board
- C. Section 07542 PVC Thermoplastic Membrane Roofing
- D. Section 07600 Sheet Metal Work

1.03 CODES AND STANDARDS:

All Codes, laws, ordinances, rules, regulations, orders, and other legal requirements of City, County, State, Federal and other public authorities which bear on performances of Work shall be applicable to The Project. Latest editions shall be applicable unless specified otherwise. Relationship between Applicable Codes and Contract Documents: The Contract Documents have been developed with the intent to conform with applicable codes. Nothing within the Contract Documents shall be construed to permit Work not conforming with applicable codes.

In accordance with the following Standards and any other applicable current Codes and Standards as described above:

ALSC	American Lumber Standards Committee
FS	Federal Specification
NBS	National Bureau of Standards
RIS	Redwood Inspection Service
UBCS	Uniform Building Code Standards
WCLIB	West Coast Lumber Inspection Bureau
WWPA	Western Wood Products Association
APA	American Plywood Association
AWPB	American Wood Preservers Bureau
AWPA	American Wood Preservers Association

1.04 QUALITY ASSURANCE:

A. Codes and Standards: Comply with all pertinent provisions of the following codes and standards:

1. Federal Specifications (Fed. Spec.)
FF-B-561C Bolts, (Screw), Lag
FF-N-105B(3) Nails, Brads, Staples, Spikes, Wire, Cut and Wrought
QQ-Z-32C Zinc Coated, Electro Deposited
2. U.S. Department of Commerce Product Standards:

PS 1-83 Construction and Industrial Plywood
PS 20-70 American Softwood Lumber Standard
3. American Forest & Paper Association (AFPA) Publications:
2004 Edition. National Design Specification for Wood Construction and Supplement, Design Values for Wood Construction.
4. Redwood Inspection Service (RIS) Publication: Standard Specifications for Grade of California Redwood Lumber, Latest Edition.
5. International Conference of Building Officials (ICBO) Publication & State of California:
6. Uniform Building Code Standards, Current Edition
7. California Code of Regulations, Latest Edition
Title 24, Part 2, California Code of Regulations
8. West Coast Lumber Inspection Bureau (WCLIB) Publication: Standard Grading Rules for West Coast Lumber, No, 17, Latest Edition
9. Western Wood Products Association (WWPA) Publication: Standard Grading Rules for Western

Lumber, Latest Edition.

- B. Conflicting Requirements: In the event of conflict between pertinent codes and regulations and the requirements of the referenced standards or these specifications, the provisions of the more stringent shall govern.
- C. Qualifications of Personnel:
 - 1. Throughout progress of the work of this section, provide at least one person thoroughly familiar with the specification requirements, completely trained and experienced in the necessary skills, and who shall be present at the site and shall direct all work performed under this section.
 - 2. In actual installation of the work under this section, use adequate numbers of skilled workmen to ensure installation in accordance with the approved design and approved recommendations of the manufacturer of the material which is being installed or applied.

1.05 SUBMITTALS:

- A. General: Make submittals in accordance with requirements of Section 01300.
- B. Pneumatically-Driven Fasteners: Submit manufacturer's literature and installation instructions and sample for review and approval.

1.06 DELIVERY AND STORAGE:

- A. Protection: Use all means necessary to protect the materials of this Section before, during and after installation, and to protect the work and materials of all other trades.
- B. Replacement: In the event of damage, immediately make all repairs and replacements necessary and at no additional cost to the Clovis Unified School District.

Deliver and store materials in dry, protected areas as directed by Clovis Unified School District. Keep free of stain or other damage. Replace any damaged material at no cost to Clovis Unified School District. When ready to install, plywood shall be placed on the roof in small stacks over column locations until applied.

PART 2 - MATERIALS

2.01 FRAMING LUMBER:

- A. Lumber shall be dry and well seasoned. The moisture content shall not exceed 19% in boards 8" or less in depth, 15% in lumber more than 8" in depth and plywood.
- B. Lumber herein referred to shall be graded and grade marked and shall conform to the following specifications, as applicable. All material shall be new.
 - 1. Douglas Fir Select Structural I. Per standard grading and dressing rules #16 of the West Coast Lumber Inspection Bureau (WCLIB).
 - 2. Plywood: Replacement sheathing, Structural I, CD (exterior glue) shall conform to the requirements designed in American Plywood Association, US Production Standard for soft plywood. Each Standard PS 1-74 size panel shall be legibly identified with appropriate grade trademark of American Plywood association, visibly shown. Do not incorporate improperly or illegibly identified plywood into the work.
 - 3. Redwood to be foundation grade or better.

2.02 PRESERVATIVES

- A. Pressure-treat above ground items with EPA approved water-borne preservatives, and in accordance with AWPB LP-2. After treatment, kiln-dry lumber and plywood to a maximum moisture content, respectively, of 19 percent and 15 percent.
- B. If items are cut after treatment, coat cut surfaces with two coats of same chemical used for treatment and to comply with AWWA M4.

2.03 MISCELLANEOUS MATERIALS:

- A. Fasteners: All nails for fastening plywood to roof supports shall be **common nails**: flat head, diamond point, hot-dipped galvanized. All nails shall be hot-dip galvanized. Federal Specification FF-N-105B.
- B. Concrete Nails: Flat countersunk head, diamond point, quench hardened steel.
- C. Mechanical Fasteners: Approved Hilti or Rawl Fasteners. Submit for approval.
- D. Wood Screws: Fed. Spec. FF-S-111D, ANSI B 18.6.1 (Galvanized Finish)
- E. Bolts and Nuts: Steel bolts complying with ASTM A-307, Grade C for structural; with ASTM A 563 hex nuts and where indicated, flat washers.
- F. Lag Screws: Fed Spec FF-B-561C
- G. Metal connectors (Joist hangers) for joist fastenings to supports shall be by Simpson Company of San Leandro, California. Nails shall also be by Simpson.
- H. Anchors to be steel sheet zinc-coated by hot dip process on continuous lines prior to fabrication to comply with ASTM A 525 for Coating Designation G 60 and ASTM A 653, SQ grade (structural quality); ASTM A 526 (commercial quality); or ASTM 527 (lock-forming quality); as standard with manufacturer for type of anchor indicated.
- I. Hangers: Simpson Strong-Tie Connectors or approved equal.

PART 3 - EXECUTION

3.01 INSPECTION:

Examine the areas and conditions under which work of this Section will be performed. Correct conditions detrimental to the proper and timely completion of the work. Do not proceed until unsatisfactory conditions have been corrected.

3.02 WOOD MATERIALS:

All materials shall be new when incorporated into the work.

3.03 WORKMANSHIP:

The entire work of this division shall be performed in accordance with the best standards of practice relating to the trade and under the constant supervision of a competent foreman who shall carefully plan and lay out the work as required to carry out the intent of the drawings and to properly accommodate the work of other trades. All lumber framing shall be accurately cut and fitted into the respective location, true to lines, grades and level as indicated or required and permanently secured in proper position with spikes, or other fastenings or fittings as

detailed to render the work substantial and rigid in all parts and connections. All framing shall comply with the requirements of the local building codes.

Do not cut, notch, or bore framing for passage of pipe, ducts, or conduit without approval of Clovis Unified School District unless specifically indicated on the Project Drawings. Prior to cutting, notching, or boring through any framing member, inquire of Clovis Unified School District's Representative if alternative is available.

3.04 FASTENING:

A. Nailing:

1. Nails in plywood shall not be overdriven to the extent that nail-heads penetrate the face ply more than the thickness of the nail head.
2. The spacing center to center of nails shall not be less than the required penetration. Edge or end distance shall not be less than one-half the required penetration. The required penetration is 11 nail diameters for Douglas Fir Lumber.
3. Do all nailing without splitting the wood. Pre-bore to a diameter smaller than the nail when required to avoid splitting. Replace all split members.
4. Nailing of replacement plywood roof sheathing shall be 6" o.c. in field and 4" o.c. on panel edges using 8d "common" galvanized nails.

3.05 CLEANING UP:

- A. Keep the premises in a neat, safe and orderly condition at all times during execution of this portion of the work, free from accumulation of sawdust, cut-ends, and debris.
- B. The entire project site grounds shall be thoroughly cleaned at the end of each day. A magnetic nail roller or strong magnet shall be used to pick-up all nails at the end of each day.

END OF SECTION 06100

DIVISION 7 – THERMAL & MOISTURE PROTECTION

SECTION 07220 - ROOF DECK GYPSUM COVER BOARD

PART 1 – GENERAL

Contractor shall provide labor, material and equipment to perform the work, including but not limited to the following:

1.01 DESCRIPTION:

A. Work Included:

1. Install one layer of preliminarily fastened ¼” dens deck directly to the plywood roof substrate in strict accordance with manufacturer requirements to meet 90mph wind up lift.

1.02 RELATED WORK SPECIFIED ELSEWHERE:

- A. Division 1 General Requirements
- B. Section 07542 PVC Thermoplastic Membrane Roofing
- C. Section 07600 Sheet Metal Work

1.03 DELIVERY AND STORAGE:

- A. Delivery: Deliver materials to the job site in manufacturer’s original packaging, containers and bundles with manufacturer’s brand name and identification intact and legible.
- B. Storage and handling: Rigid insulation and “Dens-Deck” (or approved equal) must be kept dry during storage and application. Outside storage must be off ground and protected by a breathable waterproof covering. If any material becomes wet, it must be dried before installation. Insulation and “Dens-Deck” (or approved equal) must be roofed same day as laid.

1.04 SUBMITTALS:

A. Product Data & Samples.

Submit product literature, samples, and material safety data sheets for the items specified in this Section.

B. These include:

1. Gypsum Cover Board ¼”. Provide thicker cover board if required to by roofing Materials manufacturer to comply with required Class “A” fire rating
2. Proposed Coverboard fastening pattern, Fasteners, and coverboard plates.
3. Sealant/Caulking (If applicable).
4. Shop Drawings: Submit shop drawings indicating fastener patterns for FMRC wind uplift resistance specified.
5. Certification: Submit manufacturer’s written certification that product meets specified fire-resistance requirements.

1.05 LIMITATIONS

- A. Gypsum coverboards must be kept dry at all times. Apply only as much material as can be covered by a waterproof roof membrane system the same day, or install approved waterblocks to protect exposed material. Contractor shall remove all wet or water-damaged coverboard from the project site as requested by Building Owner or its Representative.
- B. Accumulation of water due to leaks or condensation in or on gypsum coverboard must be avoided during construction and after construction. Avoid application of gypsum cover board during rains, heavy fogs and all other conditions that may deposit moisture on the surface.
- C. Conditions beyond the control of the manufacturer such as weather conditions, dew, application temperatures and techniques may cause adverse effects with adhered roofing systems. Always consult roofing manufacturer for their specific instructions on applying their products to "Dens-Deck" (or approved equal).
- D. When applying solvent-based adhesives or primers, allow sufficient time for the solvent to flash off to avoid damage to roofing components.

PART 2 – PRODUCT

2.01 GYPSUM CORE ROOF BOARD DECKING:

- A. Description: Non-structural, glass mat-embedded front and back, silicone treated core, water-resistant gypsum core panel, UL-classified Type DGG, compiling with ASTM C1177. The panel shall be specifically intended for mechanically fastened single-ply membrane systems.
- B. Acceptable product: G-P Gypsum Corporation, "Dens-Deck (or approved equal).
- C. Composition: Non-structural, fiberglass-embedded, treated gypsum core panel with facer
- D. Size: Nominal 4'-0" x 8'-0" or 4' x 4'
- E. Thickness: ¼" as indicated on drawings. (install 1/2" thickness product if required by roofing materials manufacturer based on Manufacturer warranty and required fire rating).
- F. Weight, (lbs/sq. ft.): 1.2 – 2.4
- G. Permeance (perms) (ASTM E-96): 50
- H. "R" Value (ASTM C-518): 0.28
- I. Fire Resistance: UL 1256, UL Class A
- J. Compressive Strength: 600 psi

2.02 MISCELLANEOUS FASTENERS AND ANCHORS

- A. All fasteners, anchors, nails, straps, bars, etc. shall be post-galvanized steel, aluminum or stainless-steel dependent upon the composition of the elements they are attached to or penetrating through. Mixing metal types and methods of contact shall be assembled in such a manner as to avoid galvanic corrosion. Fasteners for attachment of metal to masonry shall be expansion type fasteners with stainless steel pins. All concrete fasteners and anchors shall have a minimum embedment of 1¼ inch (32 mm) and shall be approved for such use by the fastener manufacturer. All miscellaneous wood fasteners and anchors used for flashings shall have a minimum embedment of 1 inch (25 mm) and shall be approved for such use by the fastener manufacturer.

PART 3 - EXECUTION

3.01 GENERAL:

- A. Use maximum lengths possible to minimize number and joints.
- B. Offset joints of gypsum cover board from insulation boards by minimum of 2' in all directions.
- C. Install new ¼ thickness gypsum cover board at roof areas indicated on drawings. Preliminarily Secure gypsum boards using a minimum of six (6) #14 coated fasteners with 3" smooth insulation plates approved by manufacturer requirements.
- D. Install additional plates and fastener as required by manufacturer. Install membrane fasteners and plates along the perimeter and at corner areas as required by manufacturer per required wind warranty. Coverboards shall be applied per the roofing material manufacturer's recommendations or as herein specified. Gypsum cover boards shall be installed over all tapered insulation and tapered insulation crickets and shall extend to perimeter walls.

3.02 WOOD NAILER INSTALLATION

- A. Install new wood nailers at locations shown on the project Drawings, as required by primary roofing materials manufacturer, or as required to properly install roof system, base flashings, and related flashings.
- B. Nailers shall be anchored to resist a minimum force of 300 pounds per lineal foot (4,500 Newtons/lineal meter) in any direction. Individual nailer lengths shall not be less than 3 feet (0.9 meter) long, nor more than 10' in length. Nailer fastener spacing shall be at 12 inches (0.3 m) unless indicated otherwise on project drawings. Fasteners for securement of nailers shall be staggered 1/3 the nailer width and installed within 6 inches (0.15 m) of each end. Two fasteners shall be installed at ends of nailer lengths. Nailer attachment shall meet this requirement and that of the current Factory Mutual Loss Prevention Data Sheet 1-49.
- C. Nailer thickness shall match substrate or insulation height to allow a smooth transition. Where nominal thickness lumber does not match up with insulation thickness, have lumber milled or ripped to match thickness.
- D. Any existing nailer woodwork which is to remain shall be firmly anchored in place to resist a minimum force of 300 pounds per lineal foot (4,500 Newtons/lineal meter) in any direction and shall be free of rot, excess moisture or deterioration. Only woodwork shown to be reused in Detail Drawings shall be left in place. All other nailer woodwork shall be removed.

3.03 GYPSUM COVERBOARD INSTALLATION

- A. General Criteria:
 - 1. Coverboards shall be installed according to the manufacturer's recommendations and published installation requirements.
 - 2. Do not install more insulation and/or cover board than can be covered with roof membrane and be in completely watertight condition by end of work shift, or before onset of inclement weather.
 - 3. Verify plywood substrate is free of any damage, protrusions, or any other irregularities that may interfere with the application of the coverboard and single ply roof system.

- B. Application of Gypsum Cover Board Using Low Rise Foam Adhesive:
1. Install new ¼ thickness gypsum cover board at roof areas indicated on drawings. Preliminarily Secure gypsum boards using a minimum of six (6) #14 coated fasteners with 3" smooth insulation plates approved by manufacturer requirements.
 2. Install additional plates and fastener as required by manufacturer. Install membrane fasteners and plates along the perimeter and at corner areas as required by manufacturer per required wind warranty. Coverboards shall be applied per the roofing material manufacturer's recommendations or as herein specified. Gypsum cover boards shall be installed over all tapered insulation and tapered insulation crickets and shall extend to perimeter walls.
 3. Contractor shall have manufacturer or independent testing company perform Fasteners pull out tests as required by roofing materials manufacturer. The cost of testing shall be included in the contractor's bid.

3.04 WIND UPLIFT REQUIREMENTS

- A. The roof system shall meet Factory Mutual wind uplift requirements per these specifications.
- B. Composition of roofing assembly shall match tested, rated requirements for water resistance, fire resistance, attachment and adhesion.
- C. Designed wind speed: Minimum roof covering uplift resistance in accordance with FM 4470, UL580, or UL1897:
- D. Manufacturer to determine boundaries of all perimeter and corner areas.
- E. Required wind design requirements: 90 mph wind warranty

END OF SECTION 07220

DIVISION 7 – MOISTURE PROTECTION

SECTION 07542 – PVC THERMOPLASTIC MEMBRANE ROOFING

PART 1 - GENERAL CONDITIONS

1.01 DESCRIPTION

A. Work Included:

1. Furnish all labor and materials to completely remove the existing standing seam roofing system and related flashings, as indicated on the drawings and/or as specified herein.
2. Tear off, remove, and haul away all existing roofing material, insulation, wall and base flashings, related sheet metal flashings, repairs, and mastics, as indicated on drawings, or as required to prepare the roof substrate for application of the new roof system.
3. Install layer of 1/4" thickness gypsum cover board directly over plywood and/or wood deck where indicated on drawings. Gypsum cover boards shall be secured to the roof deck using manufacturer approved plates and fasteners. Contractor shall install additional plates and fasteners as required by manufacturer based on required wind warranty. Maximum coverboard board size shall be 4' x 8', or as approved by primary roofing materials manufacturer.
6. Install additional plates, fasteners, and perimeter strips (as determined by manufacturer) in accordance with the required 90 mph wind warranty.
7. Gypsum cover boards shall be secured to walls and/or curbs using mechanical fasteners and/or approved adhesive as indicated on drawings and as required by roofing materials manufacturer.
8. Install a new mechanically fastened 80-mil reinforced PVC (ASTM D-4434) roof system with manufacturer warranty (20-year NDL-type), with reinforced PVC flashings at all perimeters, penetrations, and drain locations per project design documents, addendums, and manufacturer requirements.
9. The thermoplastic membrane shall be mechanically attached through the preliminarily fastened gypsum cover board to the roof deck. The roof system shall meet 90 mph wind uplift requirements, and the primary roofing materials manufacturer shall provide a twenty (20) year NDL type (labor and material) manufacturer warranty as specified. The contractor shall provide a three (3) year workmanship guarantee on the installation.
10. Roof system shall include all new roof-related sheet metal and new expansion joints to ensure a watertight installation of all plumbing, mechanical piping, electrical conduits, and other roof penetrations. All additional flashing and detail work shall be installed in accordance with these specifications and project drawings and will comply with Roofing Manufacturer's standard written and detail requirements. Should the roof system manufacturer require incorporation of roofing details not referenced on project drawings, Contractor shall submit manufacturer approved details for approval by Owner.

- B. The Contractor shall be solely responsible for its methods regarding demolition, shoring and bracing. This responsibility extends to the preparation of engineered designs and the ultimate performance of all shoring or bracing systems.

1.02 RELATED WORK DESCRIBED ELSEWHERE:

- A. Section 06100 – Rough Carpentry
- B. Section 07220 – Roof Gypsum Cover Board
- C. Section 07600 – Sheet Metal
- D. Section 09900 – Painting

1.03 QUALITY ASSURANCE

- A. The roofing system shall be applied only by an approved applicator of the proposed Roofing Manufacturer's material.
- B. The Roofing Manufacturer shall have a minimum of ten (10) years of experience manufacturing the specified roof membrane. The PVC membrane shall also have maintained a consistent formulation for a minimum of ten (10) years.
- C. Upon completion of the installation and the delivery to the Manufacturer by the Applicator of a certification that all work has been done in strict accordance with the contract specifications and Manufacturer's requirements, an inspection shall be made by a Technical Representative of the Manufacturer to review the installed roof system.
- D. There shall be no deviation made from the Project Specification or the approved shop drawings without prior written approval by Clovis Unified School District, and the roofing materials Manufacturer.
- E. All work pertaining to the installation of the Manufacturer's membrane and flashings shall only be completed by Applicator personnel trained and authorized by the Manufacturer in those procedures.

1.04 SUBMITTALS

Following award of contract, the Contractor shall submit to Clovis Unified School District the following:

- A. Written approval by the insulation manufacturer (as applicable) for use and performance of the product in the proposed system.
- B. Letter from the proposed Roofing Manufacturer stating that it has a minimum of ten (10) years' consistent experience in successfully manufacturing the proposed membrane. The letter shall also state that the proposed Manufacturer membrane has maintained a consistent formulation for a minimum of ten (10) years.
- C. Letter from the proposed roofing materials manufacturer stating its membrane system as specified meets Title 24 energy requirements.
- D. Certifications by manufacturers of roofing and insulating materials that all materials supplied comply with all requirements of the identified ASTM and industry standards or practices.
- E. Copy of the Manufacturer's Warranty, Applicator's Warranty, and Safety Data Sheets (SDS) for all roofing products to be installed as part of the roof system.
- F. Shop drawings shall include:
 - 1. Profile of details of flashing methods for conditions not detailed on the project drawings.

2. All details submitted by Contractor for approval shall have been reviewed and approved by primary roofing materials manufacturer.

1.05 CODE REQUIREMENTS

- A. The applicator shall submit evidence that the proposed roof system meets the requirements of the local building code and has been tested and approved or listed by the following test organizations. These requirements are of minimum standards and no roofing work shall commence without written documentation of the system's compliance, as required in the "Submittals" section of this specification.
 1. Factory Mutual Research Corporation (FM) - Norwood, MA
 2. Letter from roofing materials manufacturer stating that warranty does not exclude warranty coverage for winds below 60 mph.
 3. Underwriters Laboratories, Inc. - Northbrook, IL
 4. Class A rated assembly

1.06 PRODUCT DELIVERY, STORAGE AND HANDLING

- A. All products delivered to the job site shall be in the original unopened containers or wrappings bearing all seals and approvals.
- B. Handle all materials to prevent damage. Place all materials on pallets and fully protect from moisture.
- C. Membrane rolls shall be stored lying down on pallets and fully protected from the weather with clean canvas tarpaulins. Unvented polyethylene tarpaulins are not accepted due to the accumulation of moisture beneath the tarpaulin in certain weather conditions that may affect the ease of membrane weldability.
- D. All adhesives shall be stored at temperatures between 40° F (5° C) and 80° F (27° C) or in accordance with the requirements of the manufacturer.
- E. All flammable materials shall be stored in a cool, dry area away from sparks and open flames. Follow precautions outlined on containers or supplied by material manufacturer/supplier.
- F. All materials determined by the Clovis Unified School District, its Representative, or the Roofing Materials Manufacturer to be wet or otherwise damaged are to be removed from the job site and replaced at no cost to the Clovis Unified School District.

1.07 JOB CONDITIONS

- A. The Manufacturer's materials may be installed under certain adverse weather conditions only within the tolerances approved by the Manufacturer.
- B. Only as much new roofing as can be made weather-tight each day, including flashing and detail work, shall be installed. All seams shall be cleaned, and heat welded before leaving the job site that day. Temporary sealing of incomplete systems are to meet current industry standards.

- C. All work shall be scheduled and executed without exposing the interior building areas to the effects of inclement weather. The existing building and its contents shall be protected against project-related work. The Contractor shall be responsible for all interior damages.
- D. All surfaces to receive new insulation, membrane or flashings shall be dry. Should surface moisture be present or develop during the installation process, the Contractor shall provide the necessary equipment to dry the surface prior to application in accordance with manufacturer requirements and current industry standards.
- E. All new and temporary construction, including equipment and accessories, shall be secured in such a manner as to preclude wind blow-off and subsequent roof or equipment damage.
- F. Water stops shall be installed at the end of each day's work and shall be completely removed before proceeding with the next day's work. Water-stops shall not emit dangerous or unsafe fumes and shall not remain in contact with the finished roof as the installation progresses. Contaminated roofing materials shall be replaced at no cost to Clovis Unified School District.
- G. The Contractor is cautioned that certain Manufacturer's membranes may be incompatible with asphalt, coal tar, heavy oils, roofing cements, creosote, and some preservative materials. Such materials shall not remain in contact with the Manufacturer's membranes. The Applicator shall consult the Manufacturer regarding compatibility, precautions, and recommendations.
- H. Arrange work sequence to avoid use of newly constructed roofing as a walking surface or for equipment movement and storage. Where such access is absolutely required, the Applicator shall provide all necessary protection and barriers to segregate the work area and to prevent damage to adjacent areas. A substantial protection layer consisting of plywood over insulation board shall be provided for all new and existing roof areas that receive rooftop traffic during construction.
- I. Prior to and during application, all dirt, debris, and dust shall be removed from surfaces either by vacuuming, sweeping, blowing with compressed air and/or similar methods. If removed roofing system contain asbestos, refer to enclosed Section 02075 for requirements.
- J. The Applicator shall follow all safety regulations as required by OSHA and any other applicable authority having jurisdiction.
- K. All roofing, insulation, flashings, and metal work removed during construction shall be immediately taken off site to a legal dumping area authorized to receive such materials.
- L. All new roofing waste material (i.e., scrap roof membrane, empty cans of adhesive) shall be immediately removed from the site by the Applicator and properly transported to a legal dumping area authorized to receive such material.
- M. The Applicator shall take precautions that storage and/or application of materials and/or equipment does not overload the roof deck or building structure.
- N. Flammable adhesives and deck primers shall not be stored and not be used in the vicinity of open flames, sparks, and excessive heat.
- O. All rooftop contamination that is anticipated or that occurs shall be reported to Clovis Unified School District to determine the corrective steps to be taken.
- P. Applicator shall immediately stop work if any unusual or concealed condition is discovered and shall immediately notify Clovis Unified School District of such conditions in writing for correction at the Owner's expense.

- Q. Site cleanup, including both interior and exterior building areas that have been affected by construction, shall be completed to the Clovis Unified School District's satisfaction.
- R. All landscaped areas, including but not limited to plants, trees, sprinkler elements, concrete or other planting materials damaged by construction activities shall be repaired at no cost to Clovis Unified School District to its satisfaction.
- S. The Applicator shall conduct tests to ensure adequate adhesion of insulation boards to substrate if required by insulation manufacturer and/or roofing materials manufacturer for purposes of compliance with warranty or roof system guarantee.
- T. Cautions shall be taken when using Manufacturer approved adhesives at or near rooftop vents or air intakes. Adhesive odors could enter the building. Coordinate the operation of vents and air intakes in such a manner as to avoid the intake of adhesive odor while ventilating the building. Always keep lids on unused cans. Vents shall be sealed or isolated during work performed in proximity with use of solvent based adhesive.
- U. Protective wear, including respiratory protection, shall be worn when using solvents or adhesives where required by manufacturer of OSHA regulations. Cartridges shall be for fumes and vapors.

1.08 WARRANTIES

- A. **20 Year NDL System Warranty:** Upon successful completion of the work to the Manufacturer's satisfaction and receipt of final payment, the twenty (20) year labor and materials roof system warranty shall be issued.
- B. The Manufacturer's roof system warranty shall not exclude coverage for wind speeds of less than 90 m.p.h.
- C. Provide a three (3) year contractor workmanship guarantee.
- D. Clovis Unified School District shall notify both the Manufacturer and the roof system Applicator of any leaks as they occur during the time period when both warranties are in effect so that repairs can be made in a timely manner. Failure to notify the manufacturer and/or the contractor shall not invalidate any aspect of the warranties.

PART 2 - PRODUCTS

2.01 GENERAL

- A. Approved manufacturers for the Mechanically Fastened 80 PVC thermoplastic roof system include the following:
 - Soprema*
 - Carlisle*
 - Sika Sarnafil*
- B. Consideration of equals shall be submitted for review and acceptance by Clovis Unified School District in accordance with Clovis Unified School District's written requirements for consideration of equals. The Contractor shall submit all requested documentation, including specifications, installation instructions, technical data, physical properties, limitations, samples of each product proposed for use in conjunction with proposed manufacturer's products.

- C. Bidders submitting for acceptance of an “equal” shall provide a form comparing all physical property data for proposed product with specification requirements. Consideration of “or equals” shall be in accordance with CUSD General & Supplemental Condition requirements.

2.02 PVC MEMBRANE:

- A. A minimum 80-mil thermoplastic membrane with fiberglass and/or polyester mat reinforcement
- B. Membrane shall conform to ASTM D4434-96 (or latest revision), "Standard for Polyvinyl Chloride (PVC) Sheet Roofing". Classification: Type II, Grade I.
- C. Color of Membrane: White
- D. Approved Manufacturers & Products or the mechanically attached thermoplastic roof system includes the following for the 80 mil PVC membrane:

Sika Sarnafil – S327
Carlisle – Sure Weld
Soprema – P200

2.03 Typical Physical Properties of PVC Membrane:

<u>Parameters</u>	<u>ASTM Test Method</u>	<u>Minimum ASTM Requirement</u>
Reinforcing Material – Polyester		-
Overall Thickness, min., inches (mm)	D751	0.080
Breaking Strength min. lbf/in.	D751	110 (489)
Elongation at Break, min	D751	250 & 220
Low Temperature Bend, -40°F (-40°C)	D2136	Pass
Weight Change After Immersion in Water, max.	D570	1.79%
Static Puncture Resistance, 33 lbf (15 kg)	D5602	Pass
Solar Reflectance	C1549	> 80%
Thermal Emittance	C1371	0.88
Solar Reflective Index (SRI)	E1980	>100
Dynamic Puncture Resistance, 14.7 ft-lbf (20 J)	D5636	Pass

2.04 FLASHING MATERIALS

- A. Flashings
 - 1. Sheet Metal Flashings

PVC-coated, heat-weldable sheet metal capable of being formed into a variety of shapes and profiles. 24-gauge, G-90 galvanized clad sheet metal with a 20 mil (1 mm) unsupported manufacturer approved membrane laminated on one side.
 - 2. Non-Typical Sheet Metal Flashings Project-specific perimeter edge detail reviewed and accepted for one-time use by the Manufacturer’s Technical Department. Consult Regional Technical Manager prior to job start for review and consideration for acceptance.

3. Miscellaneous Sheet Metal Flashings (Not adhered to by thermoplastic membrane)
Min. 24-gauge, galvanized sheet metal and/or 4 lb. sheet lead flashings. See Section 07600 (Sheet Metal).
4. Flashings at roof penetrations: PVC-coated, heat-weldable sheet metal, and/or prefabricated flashing element as provided by roofing materials manufacturer which is compatible with thermoplastic membrane and existing flashing elements.

2.06 GYPSUM ROOF BOARD

- A. A ¼” thickness gypsum roof board for installation over specified plywood roof sheathing. Install ½” product where required by manufacturer based on the specified warranty.
- B. Gypsum board shall be rated by UL “Class A” for fire resistance
- C. Board shall be pre-primed and be compatible with proposed adhesive
- D. Approved Product: “Dens Deck” by Georgia Pacific, “Securock” by U.S. Gypsum, or Approved Equal

2.07 TAPERED INSULATION & TAPERED INSULATION CRICKETS

- A. One or more layers of rigid polyisocyanurate roof insulation to provide slope to drain with minimum 1/4” per foot of slope as specified at roof areas indicated on drawings.
- B. Tapered insulation in the field of roof and at crickets shall be secured to substrate using approved mechanical fasteners at specified rate. Insulation product to be approved by manufacturer for use in their fully warranted roofing system.

2.08 ATTACHMENT COMPONENTS – WALLS/CURBS

- A. Manufacturer approved plates and fasteners for attachment of gypsum cover boards to the substrate where indicated on drawings, or where indicated or as required by roofing materials manufacturer as follows:
 1. Approved Product: Corrosion resistant mechanical fasteners approved by primary roofing materials manufacturer for use in their fully guaranteed roof system.
 2. Mechanical fasteners shall be minimum #14 corrosion-resistant threaded screws with self-tapping tip. Plates shall be round or square and include a galvalume coating. Minimum plate diameter is 3”.
 3. Fastener layout shall meet manufacturer requirements based on warranty requirements square feet of surface area. Applicator shall provide additional mechanical fasteners as required by primary roofing materials manufacturers based on their minimum requirements, and as required under their warranty.
 4. Additional fasteners shall be installed as required at corner and perimeter areas per the primary roofing materials manufacturer to meet the required I-90 wind uplift rating and the manufacturer warranty requirements.
 5. Contractor may secure gypsum cover boards to walls and/or curb surfaces using approved adhesive where allowed by primary roofing materials manufacturer.

C. Manufacturer Approved Fastener

A heavy-duty, corrosion resistant fastener (with plate) used to attach wood elements to the structural plywood roof deck. The fastener shall have a shank diameter of approximately 0.21 inch (5.3 mm) and shall have a deformed shank or be an expansion type fastener appropriate for use in anchoring elements to plywood. Contractor shall submit examples of proposed fastener as part of material submittal for approval by Clovis Unified School District.

D. Manufacturer Approved Flat Pressure Bar for Walls and Curbs

An extruded aluminum, low profile bar used with manufacturer approved fasteners to attach to the walls/curbs at terminations, penetrations and at incline changes of the substrate. The pressure bar material shall be an FM approved, heavy-duty, 14 gauge, galvanized or stainless, roll-formed steel bar pre-punched with holes every 6-inches (152 mm) on center to allow various fastener spacing options. The pressure bar material shall be 1-inch (25 mm) wide, flat aluminum bar 1/8 inch (3 mm) thick. Where curbs and wall elements are of structural concrete, fasteners shall be appropriate for use in securing elements to structural concrete and shall be expansion or wedge type anchors. Alternate fastening systems by manufacturer will be acceptable as long as securement system is included as part of manufacturer system warranty.

E. Manufacturer Approved Formed Pressure Bar for Roof Decks

An extruded aluminum, low profile bar used with manufacturer approved fasteners to attach to the walls/curbs at terminations, penetrations and at incline changes of the substrate. The pressure bar material shall be an FM approved, heavy duty, 14 gauge, galvanized or stainless, roll-formed steel bar pre-punched with holes every 6-inches (152 mm) on center to allow various fastener spacing options. The pressure bar material shall be 1-inch (25 mm) wide, flat aluminum bar 1/8 inch (3 mm) thick.

2.10 SEALANTS

A. Manufacturer Approved Multi-Purpose Sealant (for flashing and termination details).

1. As approved by primary manufacturer in there fully warranted system.

B. Depending on substrates, the following sealants are options for temporary overnight tie-ins:

1. Method approved by manufacturer.

2. Spray-applied, water-resistant urethane foam (2 lb. density min.)

3. Mechanical attachment with rigid bars and compressed sealant.

C. All temporary overnight tie-ins shall be completely removed to expose uncontaminated material for installation of the new roof system. All used temporary materials shall be disposed and not reused.

2.11 MISCELLANEOUS FASTENERS AND ANCHORS

A. All fasteners, anchors, nails, straps, bars, etc. shall be post-galvanized steel, aluminum or stainless steel dependent upon the composition of the elements they are attached to or penetrating through. Mixing metal types and methods of contact shall be assembled in such a manner as to avoid galvanic corrosion. Fasteners for attachment of metal to masonry shall be expansion type fasteners with stainless steel pins. All concrete fasteners and anchors shall have a minimum

embedment of 1¼ inch (32 mm) and shall be approved for such use by the fastener manufacturer. All miscellaneous wood fasteners and anchors used for flashings shall have a minimum embedment of 1 inch (25 mm) and shall be approved for such use by the fastener manufacturer.

2.12 RELATED MATERIALS

A. Wood Nailers

Treated wood nailers shall be installed at locations indicated on drawings, and around such other roof projections and penetrations as specified on Project Drawings or as required by the roofing materials manufacturer. Existing nailers, if in good condition may be supplemented by adding new wood components. Thickness of nailers must match the insulation thickness to achieve a smooth transition. Wood nailers shall be treated for fire and rot resistance (wolmanized or osmose treated) and be #1 quality or better lumber. ***Creosote or asphalt-treated wood is not acceptable.*** Wood nailers shall conform to Factory Mutual Loss Prevention Data Sheet 1-49. All wood shall have a maximum moisture content of 19% by weight on a dry-weight basis.

B. Plywood

When bonding to plywood, a minimum ½ inch (12 mm) CDX (C side out), smooth-surfaced exterior grade plywood with exterior glue shall be used. Plywood shall have a maximum moisture content of 19% by weight on a dry weight basis.

C. Conduit Supports “Caddy” supports or approved equal

Blocking to be placed at 8’ o.c. additional blocking will be placed at direction changes and vertical transitions. All pipe clamps to be replaced with new and sized correctly for each pipe.

PART 3 – EXECUTION

3.01 PRE-CONSTRUCTION CONFERENCE

- A. The Contractor, Owner and its Representative shall attend a pre-construction conference.
 - 1. The meeting shall discuss all aspects of the project including but not limited to:
 - a. Safety
 - b. Set-up
 - c. Construction schedule
 - d. Contract conditions
 - e. Coordination of the work
 - f. Fall Protection requirements.

3.02 SUBSTRATE CONDITION

- A. Applicator shall be responsible for acceptance or provision of proper substrate to receive new roofing materials.
- B. Applicator shall verify that the work done under related sections meets the following conditions:
 - 1. Roof curbs, nailers, equipment supports, vents and other roof penetrations are properly secured and prepared to receive new roofing materials.

2. All surfaces are smooth and free of dirt, debris and incompatible materials.
3. All roof surfaces shall be free of water, ice and snow.
4. The Owner shall ensure that all roof elements are secured to the roof deck system according to local building code and in such a manner as to resist all anticipated wind loads in that location. Rigid insulation shall be adhered to the roof deck using materials and methods which will resist wind uplift forces of up to 60 mph or greater as warranted by the primary roofing materials manufacturer.

3.03 SUBSTRATE PREPARATION

- A. The roof deck and existing roof construction must be structurally sound to provide support for the new roof system. The applicator shall load materials on the rooftop in such a manner to eliminate risk of deck overload due to concentrated weight.

- B. General Criteria

All existing roofing, base flashing, deteriorated wood blocking or deteriorated metal flashings shall be removed where indicated or required to remove the existing roofing system and to install the new roof membrane, insulation and flashing systems. Remove only that amount of roofing and flashing which can be made watertight with new materials during a one-day period or before the onset of inclement weather.

3.04 SUBSTRATE INSPECTION

- A. A dry, clean and smooth substrate shall be prepared to receive the 80mil PVC roof system.
- B. The Contractor shall inspect the substrate for defects such as excessive surface roughness, contamination, structural inadequacy, or any other condition that will adversely affect the quality of work.
- C. The substrate shall be clean, smooth, dry, free of flaws, sharp edges, loose and foreign material, oil and grease. Roofing shall not start until all defects have been corrected.
- D. All roof surfaces shall be free of water, ice and snow.

3.05 GYPSUM COVER BOARD APPLICATION

- A. General Criteria: Approved Gypsum Cover Boards Mechanically Attached to Existing Roof Substrate with manufacturer approved fasteners and plates.
 1. Cover boards shall be neatly cut to fit around penetrations and projections.
 2. Cover boards shall cover all exposed insulation boards and/or plywood and wood board deck areas as indicated on drawings, including application over crickets.
 3. Do not install more cover boards than can be covered with new roof membrane by the end of the day or the onset of inclement weather.
 4. Cover boards shall be installed with all joints offset by two (2)' in all directions.
 5. Gypsum cover boards shall be secured to existing roof surface with mechanical fasteners and plates in accordance with these specifications and manufacturer requirements, with

additional plates and fasteners per manufacturer requirements. The gypsum cover boards shall be applied in such a manner as to allow the insulation boards to rest evenly on the roof substrate so that there are no significant and avoidable air spaces between the boards and the substrate.

6. Contractor shall install thickness of gypsum cover boards as required by membrane manufacturer to meet wind uplift and warranty requirements.
7. Gypsum cover boards shall be attached to vertical walls and curbs using approved mechanical fasteners or adhesive approved for use by manufacturer of gypsum cover boards and roofing materials manufacturer.

3.06 INSTALLATION OF THERMOPLASTIC MEMBRANE

The surface of the gypsum cover boards shall be inspected prior to installation of the mechanically attached PVC thermoplastic membrane. The substrate shall be clean, dry, free from debris and smooth with no surface roughness or contamination. Broken, delaminated, wet or damaged insulation and gypsum cover boards shall be removed and replaced at no cost to the Owner.

A. Manufacturer Approved Plates and Fasteners for Field of Roof

1. Over the properly installed gypsum coverboards, new pvc membrane shall be unrolled and allowed to relax prior to the installation of manufacturer approved membrane plates and fasteners. The fastening pattern shall conform to the manufacturer's requirements to obtain a 90mph wind uplift warranty and 20 yr NDL warranty requirements. Install additional perimeter strips with approved plates and fasteners to meet manufacturer requirements.
2. All membrane seams shall be heat-welded in accordance with Section 3.08

B. Manufacturer Approved Adhesive for Flashing

1. Over the properly installed and prepared substrate surface, the manufacturer approved adhesive shall be applied using solvent-resistant ¾ inch (19 mm) nap paint rollers. The adhesive shall be applied to the substrate at a rate according to the manufacturer's requirements. The adhesive shall be applied in smooth, even coating with no gaps, globs, puddles or similar inconsistencies. Only an area which can be completely covered in the same day's operations shall be coated with adhesive. The first layer of adhesive shall be allowed to dry completely prior to installing the membrane. **Do not allow the second application of adhesive to dry prior to application.**
2. When the adhesive on the substrate is dry, the roof membrane is unrolled. Adjacent sheets shall be overlapped 3 inches (75 mm). Once in place, one-half of the sheet's length shall be turned back and the underside shall be coated with manufacturer approved adhesive at a rate of ½ gallon per 100 ft² (0.2 liters/m²). When the membrane adhesive has dried slightly to produce strings when touched with a dry finger, the coated membrane shall be rolled onto the previously-coated substrate being careful to avoid wrinkles. **Do not allow adhesive on the underside of the membrane to dry completely.** The amount of membrane that can be coated with adhesive before rolling into substrate will be determined by ambient temperature, humidity and crew. The bonded sheet shall be pressed firmly in place with a water-filled, foam-covered lawn roller by frequent rolling in two directions. The remaining un-bonded half of the sheet shall be folded back and the procedure repeated.

3. The Contractor shall count the number of pails of adhesive used per area per day to verify conformance to the specified adhesive rate.
4. No adhesive shall be applied in seam areas. All membrane shall be applied in the same manner.

3.07 HOT-AIR WELDING OF SEAM OVERLAPS

A. General

1. All seams shall be hot-air welded. Seam overlaps should be 3 inches (75 mm) wide when automatic machine-welding and 4 inches (100 mm) wide when hand-welding, except for certain details. If manufacturer specifications are different, manufacturer requirements will prevail.
2. Welding equipment shall be provided by or approved by the manufacturer. All mechanics intending to use the equipment shall have successfully completed a training course provided by the Manufacturer's Technical Representative prior to welding.
3. All membrane to be welded shall be clean and dry.

B. Hand-Welding

1. Hand-welded seams shall be completed in two stages. Hot-air welding equipment shall be allowed to warm up for at least one minute prior to welding.
2. The back edge of the seam shall be welded with a narrow but continuous weld to prevent loss of hot air during the final welding.
3. The nozzle shall be inserted into the seam at a 45-degree angle to the edge of the membrane. Once the proper welding temperature has been reached and the membrane begins to "flow," the hand roller is positioned perpendicular to the nozzle and pressed lightly. For straight seams, the 40 mm wide nozzle is recommended for use. For corners and compound connections, the 20 mm wide nozzle shall be used.
4. Exercise care when heat welding to avoid melting the felt on the back of the membrane.

C. Machine Welding

1. Machine welded seams are achieved by the use of manufacturer approved automatic welding equipment. When using this equipment, the manufacturer's instructions shall be followed and local codes for electric supply, grounding and over current protection observed. Dedicated circuit house power or a dedicated portable generator is recommended. No other equipment shall be operated off the generator.
2. Metal tracks may be used over the deck membrane and under the machine welder to minimize or eliminate wrinkles.

D. Quality Control of Welded Seams

1. The Contractor shall check all welded seams for continuity using a rounded screwdriver. Visible evidence that welding is proceeding correctly is smoke during the welding operation, shiny membrane surfaces, and an uninterrupted flow of dark grey material from the underside of the top membrane. A thorough evaluation of welded seams shall be

made daily by the Contractor prior to leaving the site. Any loose, unsealed, or defective seams shall be repaired the same day. One inch (25 mm) wide cross-section samples of welded seams may be taken at least three times a day at the discretion of the Owner. Correct welds display failure from shearing of the membrane prior to separation of the weld. Each test cut shall be patched by the Contractor at no extra cost to Owner.

3.08 MEMBRANE FLASHINGS

- A. All flashings shall be installed concurrently with the roof membrane as the job progresses. No temporary flashings shall be allowed without the prior written approval of Owner or its Representative and the Manufacturer. Approval shall only be for specific locations on specific dates. If any water is allowed to enter under the newly completed roofing, the affected area shall be removed and replaced at the Applicator's expense. Flashing shall be adhered to compatible, dry, smooth, and solvent-resistant surfaces. Use caution to ensure adhesive fumes are not drawn into the building.
- B. Manufacturer Approved Adhesive for Membrane Flashings
 - 1. Over the properly installed and prepared flashing substrate, manufacturer approved adhesive shall be applied according to instructions found on the Product Data Sheet. The manufacturer approved adhesive shall be applied in smooth, even coats with no gaps, globs, or similar inconsistencies. Only an area which can be completely covered in the same day's operations shall be flashed. The bonded sheet shall be pressed firmly in place with a hand roller.
 - 2. No adhesive shall be applied in seam areas that are to be welded. All panels of membrane shall be applied in the same manner, overlapping the edges of the panels as required by welding techniques.
- C. Install new pressure bar according to the project drawings or details included in the specification with approved fasteners into the structural deck at the base of parapets, walls and curbs. New pressure bar is required at the base of all tapered edge strips and at transitions, peaks, and valleys in compliance with the project details.
- D. The Manufacturer's requirements and recommendations, in addition to these specifications shall be followed explicitly. All material submittals shall have been accepted by Owner and its Representative and the Manufacturer prior to proceeding with any work related to the project.
- E. All flashings shall extend a minimum of 6 inches (0.2 m) above roofing level unless otherwise accepted in writing by Owner or its Representative and the Roofing Material Manufacturer's Technical Department.
- F. All flashing membranes shall be consistently adhered to substrates. All interior and exterior corners and miters shall be cut and hot-air welded into place. No bitumen shall be in contact with the new roof membrane.
- G. All flashing membranes shall be mechanically fastened along the counter-flashed top edge with new pressure bar at 6-8 inches (0.15-0.20 m) on center.
- H. The Manufacturer approved flashings shall be terminated according to the Manufacturer's recommended details.
- I. All flashings that exceed 30-inches (0.75 m) in height shall receive additional securement. The Manufacturer's Technical Department shall provide securement methods.

- J. Any details necessary and/or required to properly install the roof system which are not included on the drawings shall be provided by the Contractor as part of the submittal and shall be approved in writing by the roofing materials manufacturer.
- K. Install new manufacturer approved expansion joints at all existing expansion joints and incorporate into new single ply roofing system.

3.09 METAL FLASHINGS

- A. Metal details, fabrication practices and installation methods shall conform to the applicable requirements of the following:
 - 1. Factory Mutual Loss Prevention Data Sheet 1-49 (latest issue).
 - 2. Sheet Metal and Air Conditioning Contractors National Association, Inc. (SMACNA) - latest issue.
- B. Complete all metal work in conjunction with roofing and flashings so that a watertight condition exists daily.
- C. Metal shall be installed to provide adequate resistance to bending to allow for normal thermal expansion and contraction.
- D. All metal lap joints shall be a minimum of four (4) inches. Set laps in manufacturer approved sealant. Metal joints shall be watertight. The bottom drip edge shall be ½" hemmed. All bottom edges shall be interlocked at the lap joints.
- E. Metal flashings shall be securely fastened into solid wood blocking. Fasteners shall penetrate the wood nailer a minimum of 1 inch (25 mm).
- F. Airtight and continuous metal hook strips are required behind metal fascias. Hook strips are to be fastened 12 inches (0.3 m) on center into the wood nailer or masonry wall.
- G. Counter flashings shall overlap base flashings at least 4 inches (100 mm).
- H. Hook strips shall extend past wood nailers over wall surfaces by 1½ inch (38 mm) minimum and shall be securely sealed from air entry.

3.10 METAL CLAD BASE FLASHINGS/EDGE METAL

- A. All flashings shall be installed concurrently with the roof membrane as the job progresses. No temporary flashings shall be allowed without the prior written approval of Owner or its Representative and Manufacturer. Acceptance shall only be for specific locations on specific dates. If any water is allowed to enter under the newly completed roofing due to incomplete flashings, the affected area shall be removed and replaced at the Contractor's expense.
- B. Manufacturer approved metal flashings shall be formed and installed per the project drawings or details included at the end of this section.
- C. All metal flashings shall be fastened into solid nailers with two rows of post galvanized flat head annular ring nails, 4 inches (100 mm) on center staggered. Fasteners shall penetrate the nailer a minimum of 1 inch (25 mm).

- D. Metal shall be installed to provide adequate resistance to bending and allow for normal thermal expansion and contraction.
- D . Adjacent sheets of approved manufacturer's sheet metal clad flashing material shall be spaced ¼ inch (6 mm) apart. The joint shall be covered with 2 inch (50 mm) wide aluminum tape. A 4 inch minimum (100 mm) wide strip of manufacturer approved flashing membrane shall be hot-air welded over the joint.
- E. All clad metal flashings shall be provided by the roof membrane manufacturer or approved for use with their fully guaranteed roof system.

3.11 TEMPORARY CUT-OFF

- A. All flashings shall be installed concurrently with the roof membrane in order to maintain a watertight condition as the work progresses. All temporary water stops shall be constructed to provide a 100% watertight seal. The stagger of the insulation joints shall be made even by installing partial panels of insulation. The new membrane shall be carried into the water stop. The water stop shall be sealed to the deck and/or substrate so that water will not be allowed to travel under the new or existing roofing. When work resumes, the contaminated membrane shall be cut out. All sealant, contaminated membrane, insulation fillers, etc. shall be removed from the work area and properly disposed of off -site. None of these materials shall be used in the new work.
- B. If inclement weather occurs while a temporary water stop is in place, the Contractor shall provide the labor necessary to monitor the situation to maintain a watertight condition.
- C. If any water is allowed to enter under the newly-completed roofing, the affected area shall be removed and replaced at the Contractor's expense.

3.14 COMPLETION

Prior to demobilization from the site, the work shall be reviewed by Owner or its Representative and the Contractor. All defects noted and non-compliances with these specifications shall be completed or repaired to satisfaction of CUSD and the manufacturer. All items deemed to be incomplete or unsatisfactory shall be noted in a written punch list prepared by CUSD's roofing consultant representative. These items must be corrected immediately by the Contractor to the satisfaction of Owner and its Representative and the Manufacturer's Representative prior to demobilization.

All Warranties referenced in this Specification shall have been submitted and have been accepted at time of contract award.

END OF SECTION 07542

DIVISION 7 - MOISTURE PROTECTION

SECTION 07600 - SHEET METAL WORK

PART 1 - GENERAL

1.01 SCOPE:

- A. The work required under this section consists of all shop and field fabricated sheet metal flashings and related items necessary and required to complete the work as indicated in the Contract Documents.
- B. The Contractor shall provide all items, articles, materials, operations or methods listed, mentioned or schedules on the drawings and/or specified herein, including all labor, materials, equipment, and incidentals necessary and required for this completion.
- C. The Contractor shall comply with the requirements of OSHA's Hazard Communications Standard including hazardous materials and employee training.

1.02 WORK INCLUDED:

- A. Without restricting the volume or generality of the above "Scope", the work to be performed under this section shall include, but is not limited to, the following:
 - 1. Install new sheet metal flashings and clad sheet metal flashings as noted on the project drawings and as required to properly install the specified thermoplastic roofing system and related elements.
 - 2. Replace or modify and reinstall existing sheet metal flashings where indicated on project drawings or as required based on membrane manufacturer's requirements.
 - 3. Sheet metal flashings and or coping which are to be reused shall be carefully removed and temporarily stored for reinstallation. Reused flashings to be reinstalled in watertight condition and painted per owners color choice after installation.
 - 4. Install new counter flashings and or standing seam coping as indicated on project drawings. Secure to substrate using approved corrosion-resistant rubber washer backed fasteners. Top edge of membrane to be caulked. Install in watertight condition.
 - 5. Properly support existing service lines, including condensate lines, electrical conduits, telephone lines, communication cables, plumbing lines and other rooftop elements during removal of current roof system and installation of new roofing systems. Install new or existing supports at all service lines as indicated on drawings or as required by roofing materials manufacturer.
 - 6. Refer to project drawings for miscellaneous sheet metal work not specifically addressed herein.

1.03 RELATED WORK:

- A. Section 02050 Demolition
- B. Section 06100 Rough Carpentry
- C. Section 07542 PVC Thermoplastic Membrane Roofing

1.04 REFERENCES:

- A. American Society for Testing and Materials (ASTM) Standards.
- B. Sheet Metal and Air Conditioning Contractors National Association (SMACNA) Architectural Sheet Metal Manual.

1.05 QUALITY ASSURANCE:

- A. Installer: All work of this section must be performed by a licensed sheet metal contractor with five years of successful experience with installation of sheet metal flashing and trim similar in type and scope to project requirements.
- B. Quality Standard: Fabricate and install sheet metal work in accordance with Sheet Metal and Air Conditioning Contractors' National Association, Inc. (SMACNA) "Architectural Sheet Metal Manual", unless specifically indicated otherwise.
- C. All sheet metal work shall be per SMACNA recommendations.

PART 2 - PRODUCTS

2.01 GALVANIZED SHEET STEEL:

- A. Galvanized Steel Sheet: ASTM A 526, commercial quality, G-90 hot dip galvanized. Minimum thickness: 24 gage (0.0239 inch), unless otherwise shown on the drawings or specified herein. Galvanized steel sheets shall be acid etched to receive paint finish.
- B. Steel Pipe: Steel drain pipe shall be per ASTM 760
- C. Cast Iron Pipe: Cast iron drain pipe shall be per ASTM A888-13a
- D. Cast Iron Fittings: Fittings shall be per ASTM A74-13a
- E. Factory painted metal for use in new flashings and coatings to be include Kynar® finish.

2.02 FASTENERS:

- A. Nails: Shall be hot-dipped, galvanized. All nails shall be approved type and selected for their intended use.
- B. Screws: Minimum No. 8 size screw with watertight neoprene washers under screw head where exposed shall be used for the fastening of sheet metal into wood nailers. Self-tapping, #3 sheet metal screws of ½" length shall be used for the fastening of sheet metal to sheet metal. All screws shall be of corrosion resistant metal of same material as the material being fastened. All exposed fasteners shall have 5/8" steel/neoprene washers under head.
- C. Concrete & Masonry Anchors: Hilti Hit Anchors, Rawl Zamac Nailin Hit anchors, 1-1/2" length, 1/4" diameter or approved equal shall be used for securing sheet metal to masonry or concrete surfaces.

2.03 ACCESSORY MATERIALS:

- A. Sealant: Elastomeric sealant shall be a low modulus, high performance, one part polyurethane type conforming to Federal Specifications No. TT-S-00230C, Type II, Class A, such as Sonolastic NP-1 by

Sonneborn Building Products, Sikaflex-15LM or approved equal.

- B. Solder: ASTM B 32-89, 50/50 tin-lead, rosin flux shall conform to Federal Specification O-F-506C, Type I, Form A or B.
- C. Lead Flashing: Shall be hard type, complying with Federal Specification No. QQ-L-201; weighing four pounds per square foot for roof drain flashing sheets.
- D. Copper Flashing: Shall be soft type, complying with ASTM B-370, 16 oz. for use in flashing pipe and conduit penetrations.
- E. Bituminous Coating: Heavy bodied bituminous mastic, sulfur-free, compounded for 15 mil (0.38 mm) dry film thickness per coat; inert-type non-corrosive compound, nominally free of sulfur components and other deleterious impurities.
- F. Pipe Supports: Portable Pipe Hangers or approved equal. Install support best suited to roof conditions. Contractor to submit proposed support for approval.

PART 3 - EXECUTION

3.01 EXAMINATION:

- A. Examine substrates and conditions under which products of this section are to be installed and verify that work may properly commence. Do not proceed with the work until unsatisfactory conditions have been fully resolved.
- B. Verify that nailers, blocking, and other attachment provisions for sheet metal work are properly located and securely fastened to resist effects of wind and thermal stresses.

3.02 PREPARATION:

- A. Verify shapes and dimensions of surfaces to be covered before fabricating sheet metal.
- B. Verify that surfaces to receive sheet metal are smooth, clean of all foreign matter, and have no water present in any form.

3.03 INSTALLATION:

- A. Sheet metal work shall be executed in a first-class, workmanlike manner in accordance with standard shop practices. Comply with sheet metal manufacturer's installation methods and recommendations in the SMACNA "Architectural Sheet Metal Manual".
- B. The sheet metal work shall be accurately formed to dimensions and shapes detailed or required. Broken shapes shall finish with true, straight, sharp lines, and angles; and where intersecting, shall be coped to a precise fit and be securely soldered and scraped smooth. Lock seam work shall be made flat and true to line, sweated full of solder.
- C. All sheet work shall be so formed and installed as to provide suitable allowance for expansion and contraction without causing undue stresses in any part of the completed work and shall finish water and weather tight throughout. Provide movement joints at maximum spacing of ten feet. No joints within 2 feet of corner or intersection.
- D. Mechanically fasten all joints, splices and transitions, which are not designed for expansion. Fasten metal

by solid riveting or forming double lock seams. Seal by continuous soldering.

- E. Galvanic Action Protection: Isolate different metal types from each other to prevent galvanic action.
- F. Use elastomeric sealant where necessary to make a watertight installation.
- G. Form a ½ - inch hem on the underside of all exposed edges.
- H. Fabricate cleats and attachment devices from same material as sheet metal component being anchored or from compatible, non-corrosive metal recommended by sheet metal manufacturer.
- I. The gage thickness shall be as recommended by SMACNA for application but in no case less than gage of metal being secured.

3.04 INSPECTION:

Before completing the work, the Owner or its Representative shall carefully examine, and if necessary, test all sheet metal work and equipment specified herein, and the Contractor shall make all repairs to the work if damaged, leaving it in a condition satisfactory to the Owner.

3.05 CLEAN UP:

All debris and/or rubbish resulting from the operations of this trade shall be cleaned up and removed from the site as the work progresses. The prime contractor shall be ultimately responsible for removal of refuse by all subcontractors working under their direction.

END OF SECTION 07600

DIVISION 9 - FINISHES

SECTION 09900 - PAINTING

PART 1 - GENERAL

1.01 SCOPE:

Provide all labor and materials required to complete all painting and finishing work required by the Contract Documents.

1.02 WORK INCLUDED:

Without restricting the volume or generality of the above "Scope", the work to be performed under this section shall include, but is not limited to the following:

- A. Work shall include:
 - 1. Painting of miscellaneous penetration flashings, and sheet metal elements which are part of the new roof assembly and which are visible from ground level. Contractor shall submit color samples for approval by Owner.
 - 2. Painting of exposed portions of new edge metal. Prime and paint to match building finish.
- B. The work required under this section consists of all roofing related items necessary and required to complete the work as indicated in the Contract Documents.
- C. The Contractor shall comply with the requirements of OSHA's Hazard Communications Standard including hazardous materials and employee training.
- D. The Contractor shall provide all items, articles, materials, operations, or methods listed, mentioned, or scheduled on the drawings and/or specified herein, including all labor, materials, equipment, and incidentals necessary and required for their completion.
- E. All painted finishes to match existing building finish.

1.03 RELATED WORK SPECIFIED ELSEWHERE:

- A. Division 1 General Requirements
- B. Section 06100 Rough Carpentry
- C. Section 07542 PVC Thermoplastic Membrane Roofing
- D. Section 07600 Sheet Metal Work

1.04 QUALITY ASSURANCE:

- A. Comply with all state and local regulations governing the use of paint materials. All paint primers and finishes will comply with California Air Resource Board and Environmental Protection Agency regulations.

1.05 PRODUCT DELIVERY, STORAGE, AND HANDLING:

- A. Deliver materials to job site in unopened containers bearing manufacturer's name and product description.

- B. Store materials in a dry, clean, well ventilated area. Close containers.

PART 2 - PRODUCTS

2.01 PAINT MATERIALS:

- A. Acceptable Manufacturers:

- Sinclair Paint Company (ICI Paint Stores)
- Dunn-Edwards Paint Corporation
- Sherwin-Williams Co.
- (Or Approved Equal)

2.02 EXTERIOR PAINT SYSTEMS:

Provide following paint systems for various substrate as indicated:

A. Zinc Coated Metal & Lead Flashings:

Pretreatment - (ICI Sinclair Vinyl Wash Primer, Dunn-Edwards Galva-Etch GE 123, Sherwin Williams B50W3).

1st coat - Primer Coat. (ICI Devoe Devguard #4120, Dunn-Edwards W 711, Sherwin Williams B42N8).

2nd coat - Water base acrylic, semi-gloss enamel finish coat (ICI Sinclair #2406 Decrashield Semigloss Finish, Dunn-Edwards W901, Sherwin Williams A84)

3rd coat - Water base acrylic, semi-gloss enamel finish coat (ICI Sinclair #2406 Decrashield Semigloss Finish, Dunn-Edwards W901, Sherwin Williams A84)

Where specified products are not available, Contractor may submit approved equal

B. Factory Painted Metal:

All factory painted metal used for fabrication of new coping and/or flashings shall have Kynar® finish.

C. Wood:

1st Coat - Exterior Wood Primer (ICI Sinclair Ultra-Hide Durus #2110, Dunn- Edwards W 42-1, Sherwin Williams Y24W20).

2nd Coat - Water base acrylic, semi-gloss enamel finish coat (ICI Sinclair #2406 Decrashield Semigloss Finish, Dunn-Edwards W901, Sherwin Williams A84)

3rd Coat - Water base acrylic, semi-gloss enamel finish coat (ICI Sinclair #2406 Decrashield Semigloss Finish, Dunn-Edwards W901, Sherwin Williams A84)

Where specified products are not available, Contractor may submit approved equal

2.03 SUBMITTALS/SUBSTITUTIONS:

Contractor shall provide product information (manufacturer, type, product number, etc...) and material safety

data sheets for review and approval.

PART 3 - EXECUTION:

3.01 CONDITION OF SURFACES:

Examine surfaces scheduled to receive paint and finishes for conditions that will adversely affect execution, permanence and quality of work. Do not apply paint or finish until conditions are satisfactory.

3.02 PREPARATION:

- A. Prepare surfaces in a skillful manner to produce finish work of first class appearance and durability.
- B. Clean surfaces free of dust, dirt, oil, grease and other foreign matter prior to the application of the prime coat.
- C. Repair all voids, nicks, cracks, dents, etc., with suitable patching material and finish flush to adjacent surface.

3.03 APPLICATION:

- A. Apply material evenly, free from sags, runs, crawls, holidays or defects.
- B. Apply paint by brush, roller or spray.
- C. Employ coats and undercoats for all types of finishes in strict accordance with the recommendations of the paint manufacturer.
- D. Allow each coat to dry before succeeding coat application.

3.04 REINSTALLATION OF REMOVED ITEMS:

Following completion of painting each space, promptly reinstall all items removed for painting, using only workmen skilled in the particular trade.

3.05 CLEANING:

Remove all surplus materials and debris from site at completion of each days work. Remove all paint spatter from all finish and ground surfaces.

END OF SECTION 09900

CLOVIS UNIFIED SCHOOL DISTRICT

1250 E LIBERTY HILL RD, FRESNO, CA 93720

REROOF OF LIBERTY ELEMENTARY SCHOOL MULTIPURPOSE ROOM AND SNACK BAR FRESNO COUNTY

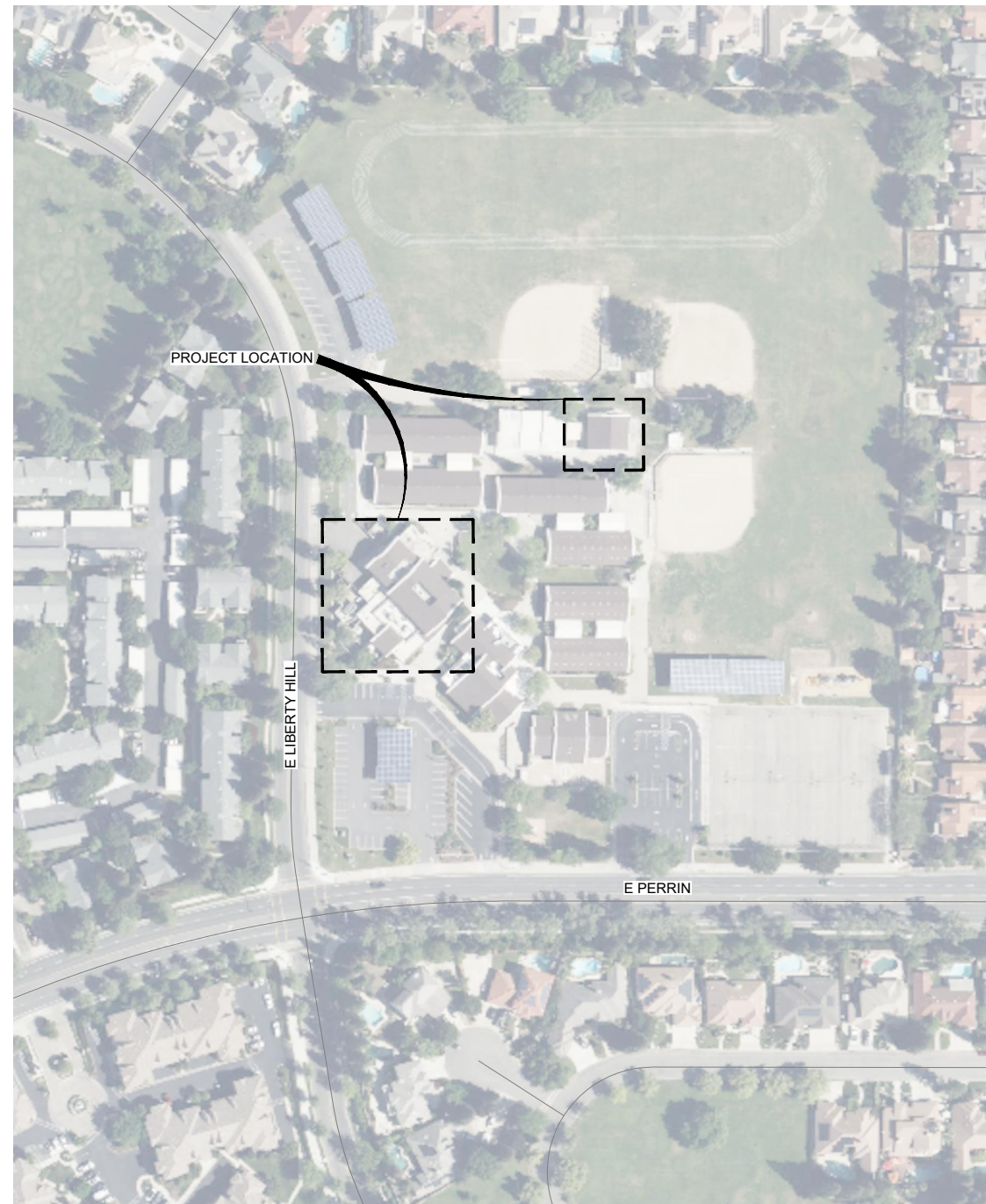
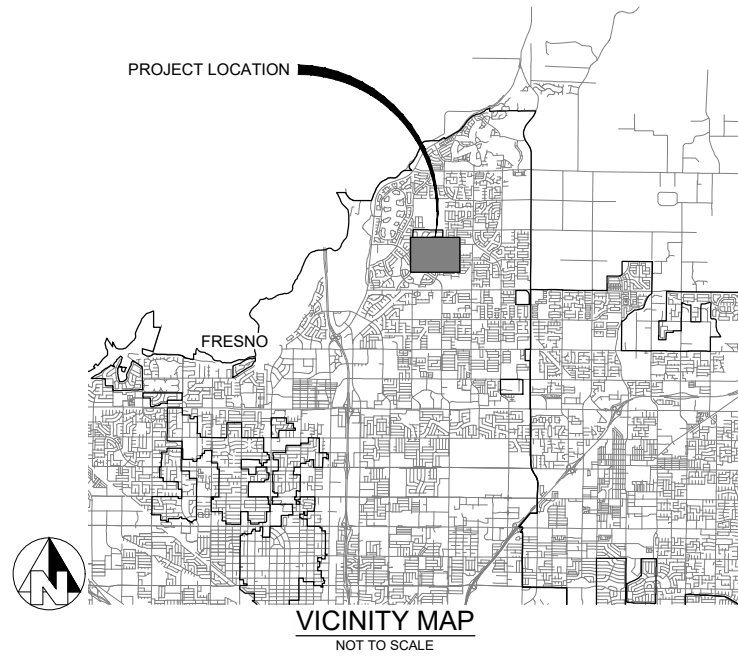

APPLICABLE CODES

ALL WORK AND MATERIALS SHALL BE PERFORMED AND INSTALLED IN COMPLIANCE WITH THE FOLLOWING CODES AS ADOPTED AND AMENDED BY THE GOVERNING JURISDICTION.

APPLICABLE SECTIONS OF THE CALIFORNIA ENERGY CONSERVATION STANDARDS

- Title 24, CCR, PART 1, 2022 Building Standards Administrative Code
- Title 24, CCR, Part 2, 2022 CBC
- Title 24, CCR, Part 3, 2022 CEC
- Title 24, CCR, Part 4, 2022 CMC
- Title 24, CCR, Part 5, 2022 CPC
- Title 24, CCR, Part 9, 2022 CFC
- Title 24, CCR, Part 12, 2022 California Referenced Standards Code
- Title 19, CCR, 2022, Public Safety, State Fire Marshall Regulations

GENERAL NOTES

1. PROVIDE THE LABOR, MATERIALS, ADMINISTRATION, FACILITIES, EQUIPMENT, TRANSPORTATION, INSURANCE, LICENCES, PERMITS, & EXPERTISE NECESSARY TO INTEGRATE THE WORK INTO THE TOTAL BUILDING SO THAT NO LEAKAGE INTO THE ROOF SYSTEM OR BUILDING OCCURS.
2. DO NOT ALLOW ANY ROOF LEAK TO INTERRUPT SCHOOL.
3. ALL WORK IS TO BE COORDINATED WITH CUSD.
4. SECURE & PAY FOR REQUIRED PERMITS, LICENCES, & INSPECTIONS. SECURE & PAY FOR REQUIRED PERMITS, LICENCES, & INSPECTIONS.
5. SUPERVISE & DIRECT THE WORK USING THE BEST SKILL & ATTENTION.

GENERAL NOTES

1. REMOVE EXISTING BUILT UP ROOFING SYSTEM, UNDERLYING 1/2" WOOD FIBER BOARD AND ALL RELATED ELEMENTS DOWN TO STRUCTURAL DECK AND DISPOSE OF OFFSITE. INSTALL NEW MINIMUM FASTENED 1/4" GYPSUM COVER BOARD DIRECTLY TO WOOD DECK. INSTALL NEW MECHANICALLY FASTENED 80MIL PVC MEMBRANE ROOF SYSTEM WITH MANUFACTURER APPROVED ACCESSORIES AS REQUIRED BY MANUFACTURER TO MEET THEIR 20-YEAR NDL WARRANTY REQUIREMENTS.
2. REMOVE EXISTING 2-PIECE REGLET COUNTER FLASHING, SAVE FOR REINSTALLATION, REINSTALL UPON COMPLETION OF MANUFACTURER APPROVED VERTICAL WALL TERMINATIONS.
3. REMOVE EXISTING PARAPET WALL COPING AND SAVE FOR REINSTALLATION. VERTICAL WALL TERMINATIONS AT PARAPET WALL ARE TO BE TERMINATED ON THE OUTER SIDE OF THE PARAPET. REINSTALL COPING IN THE ORDER IT WAS REMOVED TAKING CARE TO NOT CAUSE DAMAGE. SEAL COPING JOINTS WITH MANUFACTURER APPROVED URETHANE SEALANT AND PAINT COPING. (OWNER TO PROVIDE COLOR)
4. INCORPORATE EXISTING ROOF CURBS INTO THE NEW 80MIL PVC ROOF SYSTEM WITH MANUFACTURER APPROVED MATERIALS IN A MANNER THAT MEETS MANUFACTURER WARRANTY REQUIREMENTS.
5. INCORPORATE EXISTING HEAT STACKS INTO THE NEW 80MIL PVC ROOF SYSTEM WITH MANUFACTURER APPROVED MATERIALS IN A MANNER THAT MEETS MANUFACTURER WARRANTY REQUIREMENTS. INSTALL NEW 24G GALVANIZED STORM COLLAR.
6. REMOVE AND DISPOSE OF EXISTING T TOP VENTS. INSTALL NEW MANUFACTURER APPROVED PVC CLAD METAL VENTS.
7. REMOVE 1-2 COURSES OF ASPHALT SHINGLE AT WALL LOCATIONS. INSTALL NEW PVC CLAD METAL FLASHING AND FASTEN TO ASPHALT SHINGLE ROOF DECK. STRIP IN WITH 8" WIDE STRIP OF SELF-ADHERED WATERPROOF MEMBRANE AND REPLACE SHINGLES IN LIKE KIND. (MATCH COLOR OR SIMILAR)
8. INSTALL NEW MANUFACTURER APPROVED BOOT TO VERTICAL PIPE PENETRATIONS PER MANUFACTURER REQUIREMENTS.
9. REMOVE EXISTING ROOF MATERIAL FROM DRAIN SUMPS AND OVERFLOW PIPES, PREPARE ROOF DRAINS AND OVERFLOW PIPES AS REQUIRED AND INCORPORATE INTO NEW PVC ROOF MEMBRANE SYSTEM.
10. REMOVE EXISTING SCREEN SUPPORT SLEEPER FLASHINGS IN MANNER TO PREVENT DAMAGE. TERMINATE PVC MEMBRANE AT TOP EDGE OF SUPPORT WITH MANUFACTURER APPROVED URETHANE SEALANT AND ALUMINUM TERMINATION BAR. REINSTALL SLEEPER FLASHINGS WITH NEW FASTENERS IN LIKE KIND. INSTALL URETHANE SEALANT AT JOINTS.
11. REMOVE 1-2 COURSES OF ASPHALT SHINGLE ROOF SYSTEM FROM VERTICAL WALL AT TOP EDGE OF BASE FLASHING. INSTALL NEW 80 MIL PVC VERTICAL FLASHINGS AND TERMINATE PER MANUFACTURER REQUIREMENTS. STRIP IN TOP EDGE OF PVC MEMBRANE WITH 8" WIDE STRIP OF SELF-ADHERED WATERPROOF MEMBRANE AND INSTALL NEW ASPHALT SHINGLE IN LIKE KIND AND COLOR. INSTALL IN MANNER TO FLASH PVC WALL MEMBRANE WITH ONE COURSE OF ASPHALT SHINGLE.
12. INSTALL MANUFACTURER APPROVED PVC COMPATIBLE PREMANUFACTURED PITCH PAN AROUND THROUGH ROOF PENETRATION. HEIGHT TO BE A MINIMUM OF 2" ABOVE EXISTING SEALANT AND FILL WITH MANUFACTURER APPROVED POURABLE SEALANT AND NON SHRINKING GROUT.
13. REMOVE AND DISPOSE OF EXISTING COPING. INSTALL NEW 24G KYNAR COPING AT SNACK BAR. (MATCH EXISTING PROFILE - MATCH BUILDING FINISH)
14. ATTENDANCE AT SCHEDULED PRE-BID WALK-THROUGH IS MANDATORY TO SUBMIT A BID FOR THE PROJECT.
15. QUALITY ASSURANCE SHALL BE PROVIDED BY PROVOST AND PRITCHARD, THE OWNER'S REPRESENTATIVE.
16. CONTRACTOR SHALL PROVIDE A GUARANTEE TO MAINTAIN THE ROOF SYSTEM IN WATERTIGHT CONDITION FOR A PERIOD OF THREE (3) YEARS IN ACCORDANCE WITH THE PROJECT SPECIFICATIONS.
17. PROVIDE 20-YEAR MANUFACTURER NDL WARRANTY.
18. ALL INFORMATION CONTAINED IN THE PROJECT SPECIFICATIONS, DRAWINGS, AND ADDENDA SHALL BE CONSIDERED A PART OF AND SUPPLEMENTARY TO THE OUTLINE OF THE PROJECT AND SHALL BE INCLUDED IN THE BID FOR THE WORK.
19. ALL DIMENSIONS INDICATED ON THE DRAWINGS ARE NOMINAL. CONTRACTOR SHALL BE RESPONSIBLE FOR ACCURATE MEASUREMENTS AT THE PROJECT SITE DURING THE SCHEDULED WALK-THRU.

Sheet List Table		
NUMBER	SHEET	DESCRIPTION
GENERAL		
1	G1	COVER
ARCHITECTURAL		
2	AR1	MPR REROOF PLAN
3	AR2	SNACK BAR REROOF PLAN
4	A500	CONSTRUCTION DETAILS

FOR CONSTRUCTION
4-5-24

REROOF OF LIBERTY ELEMENTARY SCHOOL
MULTIPURPOSE ROOM AND SNACK BAR
CLOVIS UNIFIED SCHOOL DISTRICT
FRESNO COUNTY
GENERAL
COVER

PROVOST & PRITCHARD
REGISTERED ARCHITECTS
CLOVIS, CA 93720
PHONE (559) 448-2700
FAX (559) 448-2715
www.provostandpritchard.com

DESIGN ENGINEER:
TROY BROOKS

DRAFTED BY: IR
CHECKED BY: SB

DATE: 4-5-24

JOB NO: 1087-24001

PROJECT NO: 1087-24001

PHASE: ROOF

ORIGINAL SCALE SHOWN IS ONE INCH. ADJUST SCALE FOR REDUCED OR ENLARGED PLANS.

SHEET **G1**

1 OF 4

COPYRIGHT 2024 BY PROVOST & PRITCHARD ENGINEERING GROUP, INC. ALL RIGHTS RESERVED.
The firm of Provost & Pritchard Engineering Group, Inc. expressly warrants that the drawings, specifications, and other documents prepared by it for the project are true and correct as they appear on the face of these plans. These plans are not to be reproduced, changed or copied in any form or manner whatsoever, nor are they to be used for any other project without the written consent of Provost & Pritchard Engineering Group, Inc. In the event of unauthorized reuse of these plans by a third party, the firm and its members shall be held liable for any damages, including reasonable attorneys' fees, incurred by the owner. The firm and its members shall be held liable for any damages, including reasonable attorneys' fees, incurred by the owner. The firm and its members shall be held liable for any damages, including reasonable attorneys' fees, incurred by the owner.

MPR REROOF PLAN

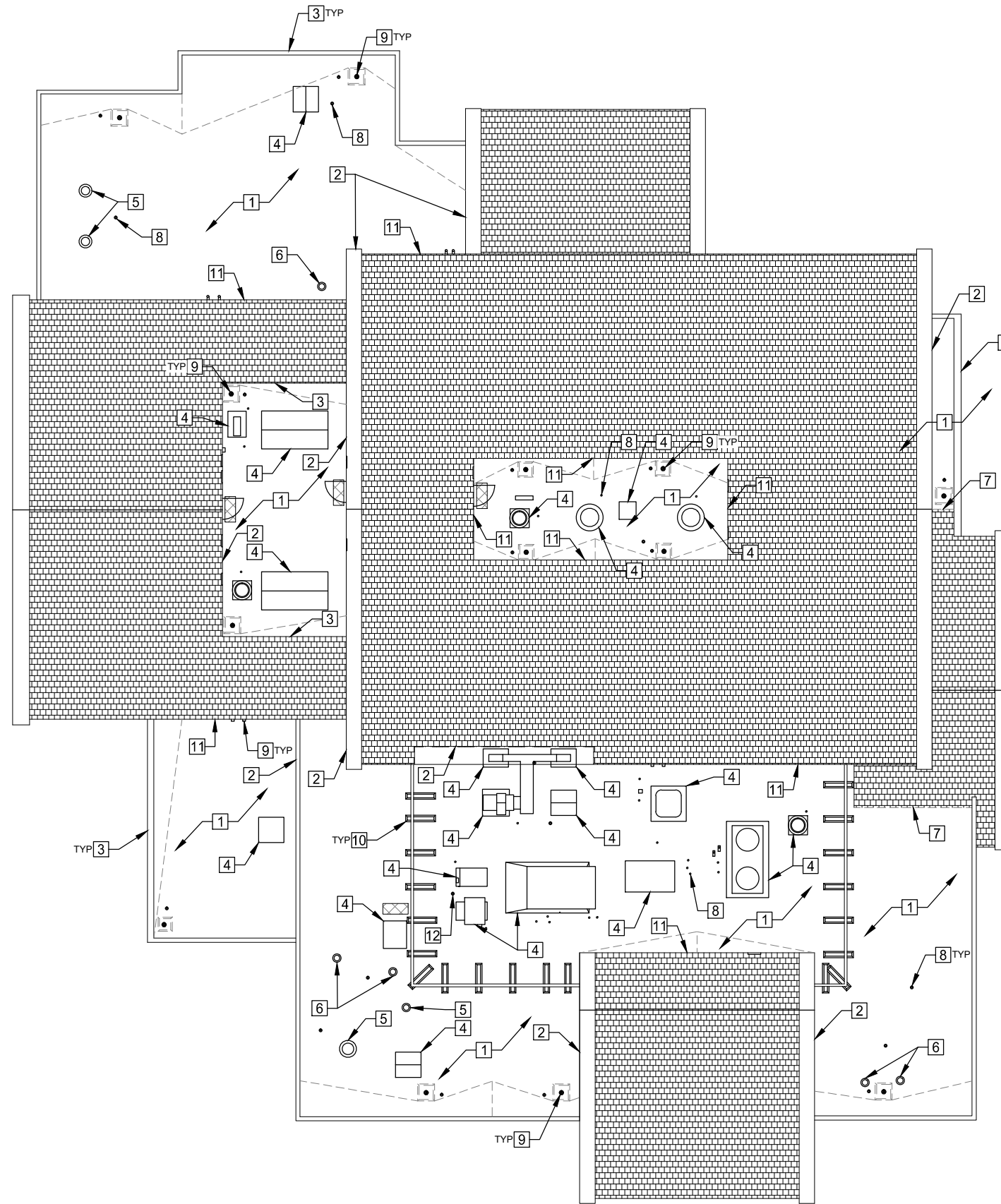

KEY NOTES - MPR

1. REMOVE EXISTING BUILT UP ROOFING SYSTEM, UNDERLYING 1/2" WOOD FIBER BOARD AND ALL RELATED ELEMENTS DOWN TO STRUCTURAL DECK AND DISPOSE OF OFFSITE. INSTALL NEW PRELIMINARY FASTENED 1/4" GYPSUM COVER BOARD DIRECTLY TO WOOD DECK. INSTALL NEW MECHANICALLY FASTENED 80MIL PVC MEMBRANE ROOF SYSTEM WITH MANUFACTURER APPROVED ACCESSORIES AS REQUIRED BY MANUFACTURER TO MEET THEIR 20-YEAR NDL WARRANTY REQUIREMENTS.
2. REMOVE EXISTING 2-PIECE REGLET COUNTER FLASHING, SAVE FOR REINSTALLATION, REINSTALL UPON COMPLETION OF MANUFACTURER APPROVED VERTICAL WALL TERMINATIONS. REFER TO DETAIL 6 A500
3. REMOVE EXISTING PARAPET WALL COPING AND SAVE FOR REINSTALLATION. VERTICAL WALL TERMINATIONS AT PARAPET WALL ARE TO BE TERMINATED ON THE OUTER SIDE OF THE PARAPET. REINSTALL COPING IN THE ORDER IT WAS REMOVED TAKING CARE TO NOT CAUSE DAMAGE. SEAL COPING JOINTS WITH MANUFACTURER APPROVED URETHANE SEALANT AND PAINT COPING. (OWNER TO PROVIDE COLOR)
4. INCORPORATE EXISTING ROOF CURBS INTO THE NEW 80MIL PVC ROOF SYSTEM WITH MANUFACTURER APPROVED MATERIALS IN A MANNER THAT MEETS MANUFACTURER WARRANTY REQUIREMENTS. REFER TO DETAIL 4 A500
5. INCORPORATE EXISTING HEAT STACKS INTO THE NEW 80MIL PVC ROOF SYSTEM WITH MANUFACTURER APPROVED MATERIALS IN A MANNER THAT MEETS MANUFACTURER WARRANTY REQUIREMENTS. INSTALL NEW 24G GALVANIZED STORM COLLAR. REFER TO DETAIL 5 A500
6. REMOVE AND DISPOSE OF EXISTING T TOP VENTS. INSTALL NEW MANUFACTURER APPROVED PVC CLAD METAL VENTS.
7. REMOVE 1-2 COURSES OF ASPHALT SHINGLE. INSTALL NEW PVC CLAD METAL FLASHING AND FASTEN TO ASPHALT SHINGLE ROOF DECK. STRIP IN WITH 8" WIDE STRIP OF SELF-ADHERED WATERPROOF MEMBRANE AND REPLACE SHINGLES IN LIKE KIND AND COLOR. REFER TO DETAIL 1 A500
8. INSTALL NEW MANUFACTURER APPROVED BOOT TO VERTICAL PIPE PENETRATIONS PER MANUFACTURER REQUIREMENTS. REFER TO DETAIL 3 A500
9. REMOVE EXISTING ROOF MATERIAL FROM DRAIN SUMPS AND OVERFLOW PIPES. PREPARE ROOF DRAINS AND OVERFLOW PIPES AS REQUIRED AND INCORPORATE INTO NEW PVC ROOF MEMBRANE SYSTEM. REFER TO DETAIL 2 A500
10. REMOVE EXISTING SCREEN SUPPORT SLEEPER FLASHINGS IN MANNER TO CAUSE DAMAGE. TERMINATE PVC MEMBRANE AT TOP EDGE OF SUPPORT WITH MANUFACTURER APPROVED URETHANE SEALANT AND ALUMINUM TERMINATION BAR. REINSTALL SLEEPER FLASHINGS WITH NEW FASTENERS IN LIKE KIND. INSTALL URETHANE SEALANT AT JOINTS.
11. REMOVE 1-2 COURSES OF ASPHALT SHINGLE ROOF SYSTEM FROM VERTICAL WALL AT TOP EDGE OF BASE FLASHING. INSTALL NEW 80 MIL PVC VERTICAL FLASHINGS AND TERMINATE PER MANUFACTURER REQUIREMENTS. STRIP IN TOP EDGE OF PVC MEMBRANE WITH 8" WIDE STRIP OF SELF-ADHERED WATERPROOF MEMBRANE AND INSTALL NEW ASPHALT SHINGLE IN LIKE KIND AND COLOR. INSTALL IN MANNER TO FLASH PVC WALL MEMBRANE WITH ONE FULL COURSE OF ASPHALT SHINGLE. REFER TO DETAIL 8 A500
12. INSTALL MANUFACTURER APPROVED PREMANUFACTURED PITCH PAN BOX AROUND THROUGH ROOF PENETRATION. HEIGHT TO BE A MINIMUM OF 2" ABOVE EXISTING SEALANT AND FILL WITH MANUFACTURER APPROVED POURABLE SEALANT.



COPYRIGHT 2004 BY PROVOST & PRITCHARD ENGINEERING GROUP, INC. ALL RIGHTS RESERVED.
 The firm of Provost & Pritchard Engineering Group, Inc. expressly warrants that the drawings, specifications, and other documents prepared by it for the project are true and correct to the best of its knowledge and belief at the time of preparation. These documents are not to be reproduced, changed or copied in any form or manner whatsoever, nor are they to be used for any other project without the prior written consent of Provost & Pritchard Engineering Group, Inc. In the event of unauthorized reuse of these plans by a third party, the firm and its employees shall be held liable for damages. Provost & Pritchard Engineering Group, Inc. legal fees associated with defending and enforcing these rights.

FOR CONSTRUCTION 4-5-24	REVISION No. BY DATE
-----------------------------------	-------------------------

REROOF OF LIBERTY ELEMENTARY SCHOOL
MULTIPURPOSE ROOM AND SNACK BAR
 CLOVIS UNIFIED SCHOOL DISTRICT
 FRESNO COUNTY
 ARCHITECTURAL
MPR REROOF PLAN

PROVOST & PRITCHARD
 ARCHITECTURAL
 1005 N. W. AVENUE
 CLOVIS, CA 93611-3166
 PHONE (559) 448-2700
 FAX (559) 448-2715
 www.provostandpritchard.com

DESIGN CONSULTANT: TROY BROOKS	
DRAFTED BY: IR	CHECKED BY: SB
DATE: 4-5-24	
JOB NO: 1087-24001	
PROJECT NO: 1087-24001	
PHASE: ROOF	
ORIGINAL SCALE SHOWN IS ONE INCH. ADJUST SCALE FOR REDUCED OR ENLARGED PLANS.	
SHEET AR1	
2 OF 4	

SNACK BAR REROOF PLAN

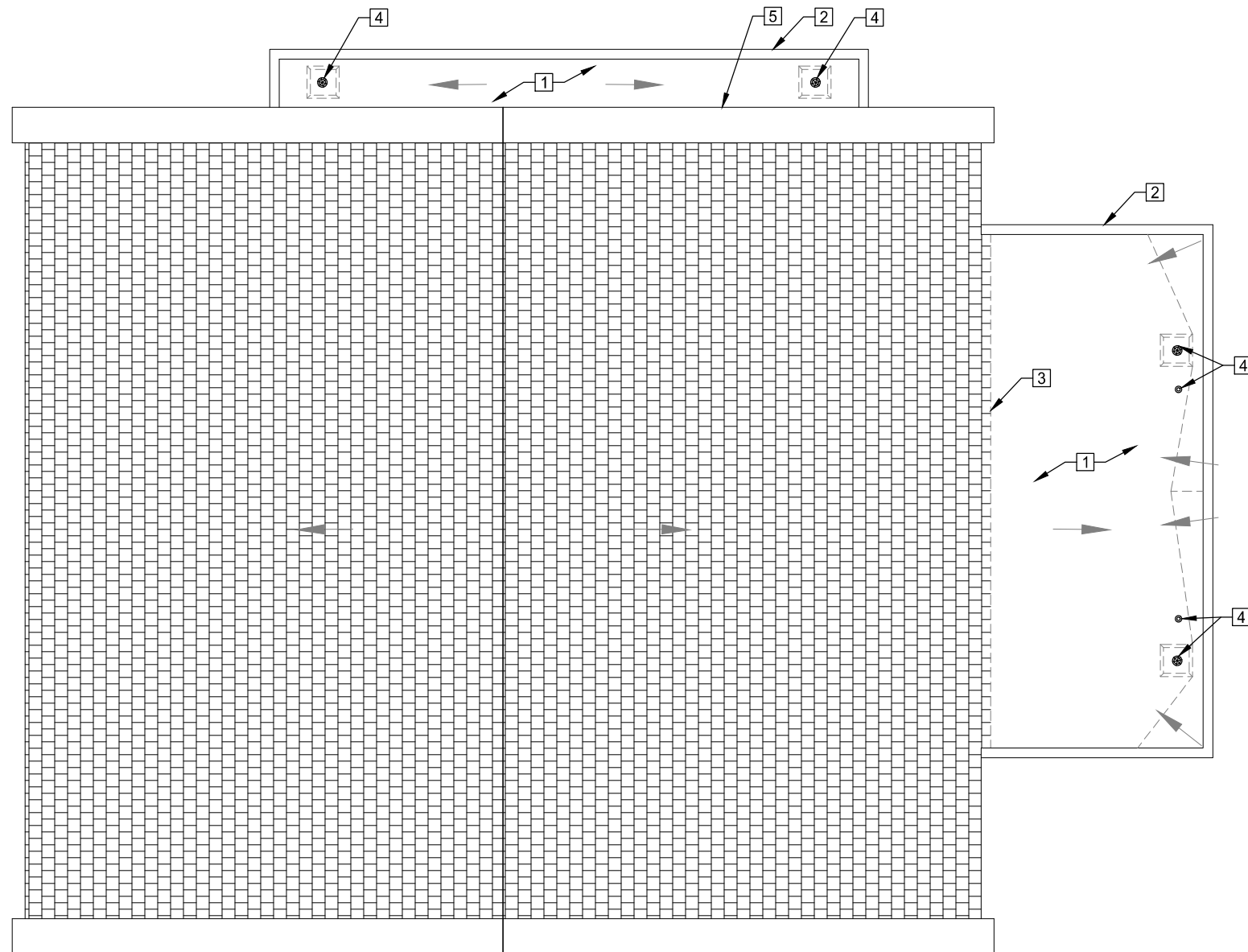

KEY NOTES - SNACK BAR

1. REMOVE EXISTING BUILT UP ROOFING SYSTEM, UNDERLYING 1/2" WOOD FIBER BOARD AND ALL RELATED ELEMENTS DOWN TO STRUCTURAL DECK AND DISPOSE OF OFFSITE. INSTALL NEW PRELIMINARY FASTENED 1/4" GYPSUM COVER BOARD DIRECTLY TO WOOD DECK. INSTALL NEW MECHANICALLY FASTENED 80MIL PVC MEMBRANE ROOF SYSTEM WITH MANUFACTURER APPROVED ACCESSORIES AS REQUIRED BY MANUFACTURER TO MEET THEIR 20-YEAR NDL WARRANTY REQUIREMENTS.
2. REMOVE AND DISPOSE OF EXISTING COPING. INSTALL NEW 24G KYNAR COPING. (MATCH EXISTING PROFILE) REFER TO DETAIL 7
A500
3. REMOVE 1-2 COURSES OF ASPHALT SHINGLE. INSTALL NEW PVC CLAD METAL FLASHING AND FASTEN TO ASPHALT SHINGLE ROOF DECK. STRIP IN WITH 8" WIDE STRIP OF SELF-ADHERED WATERPROOF MEMBRANE AND REPLACE SHINGLES IN LIKE KIND. (MATCH COLOR) REFER TO DETAIL 1
A500
4. REMOVE EXISTING ROOF MATERIAL FROM DRAIN SUMPS AND OVERFLOW PIPES. PREPARE ROOF DRAINS AND OVERFLOW PIPES AS REQUIRED AND INCORPORATE INTO NEW PVC ROOF MEMBRANE SYSTEM. REFER TO DETAIL 2
A500
5. REMOVE EXISTING 2-PIECE REGLET COUNTER FLASHING, SAVE FOR REINSTALLATION, REINSTALL UPON COMPETITION OF MANUFACTURER APPROVED VERTICAL WALL TERMINATIONS. REFER TO DETAIL 6
A500

COPYRIGHT 2024 BY PROVOST & PRITCHARD ENGINEERING GROUP, INC. ALL RIGHTS RESERVED.
 The firm of Provost & Pritchard Engineering Group, Inc. expressly warrants that the information contained herein was prepared by or copied in any form or manner whatsoever, nor are they to be reproduced, stored in a retrieval system, or transmitted in any form or by any means, electronic, mechanical, photocopying, recording, or by any information storage and retrieval system, without the prior written permission of Provost & Pritchard Engineering Group, Inc. In the event of unauthorized reuse of these plans by a third party, the firm and its employees shall be held liable for any damages, including reasonable attorneys' fees and costs of litigation, and the firm shall be entitled to enforce these rights.

FOR CONSTRUCTION 4-5-24	REVISION No. BY DATE
-----------------------------------	-------------------------

**REROOF OF LIBERTY ELEMENTARY SCHOOL
 MULTIPURPOSE ROOM AND SNACK BAR**
 CLOVIS UNIFIED SCHOOL DISTRICT
 FRESNO COUNTY
 ARCHITECTURAL
SNACK BAR REROOF PLAN

PROVOST & PRITCHARD
 ARCHITECTURAL
 1005 WEST AVENUE
 CLOVIS, CA 93611-3166
 PHONE (559) 448-2700
 FAX (559) 448-2715
 www.provostandpritchard.com

DESIGN CONSULTANT: TROY BROOKS	
DRAFTED BY: IR	CHECKED BY: SB
DATE: 4-5-24	
JOB NO: 1087-24001	
PROJECT NO: 1087-24001	
PHASE: ROOF	
ORIGINAL SCALE SHOWN IS ONE INCH. ADJUST SCALE FOR REDUCED OR ENLARGED PLANS.	
SHEET AR2	
3	OF 4

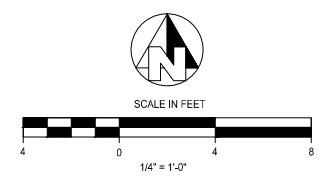

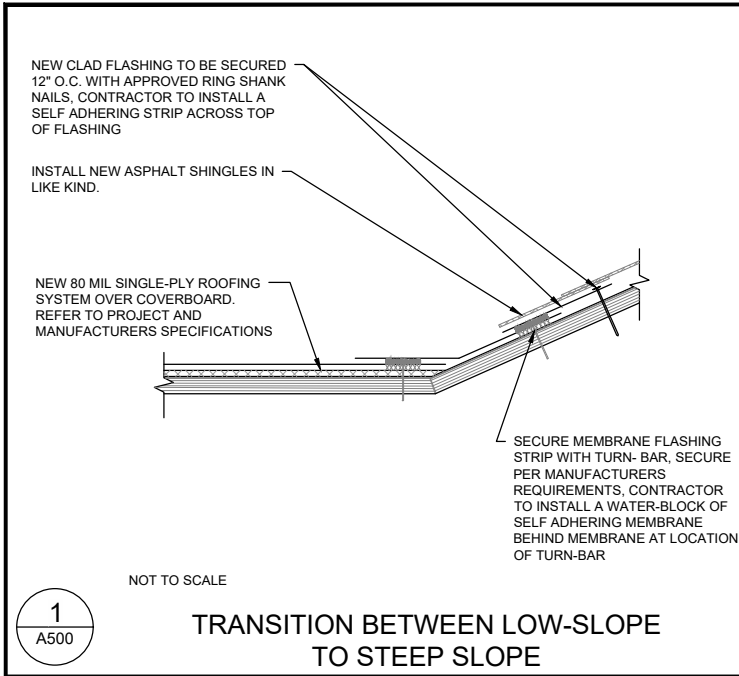

1 A500 TRANSITION BETWEEN LOW-SLOPE TO STEEP SLOPE

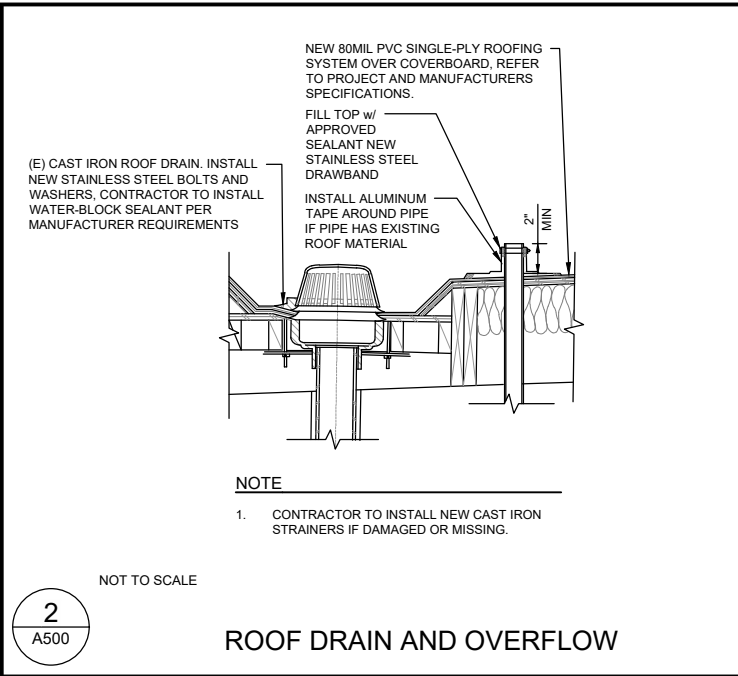

2 A500 ROOF DRAIN AND OVERFLOW

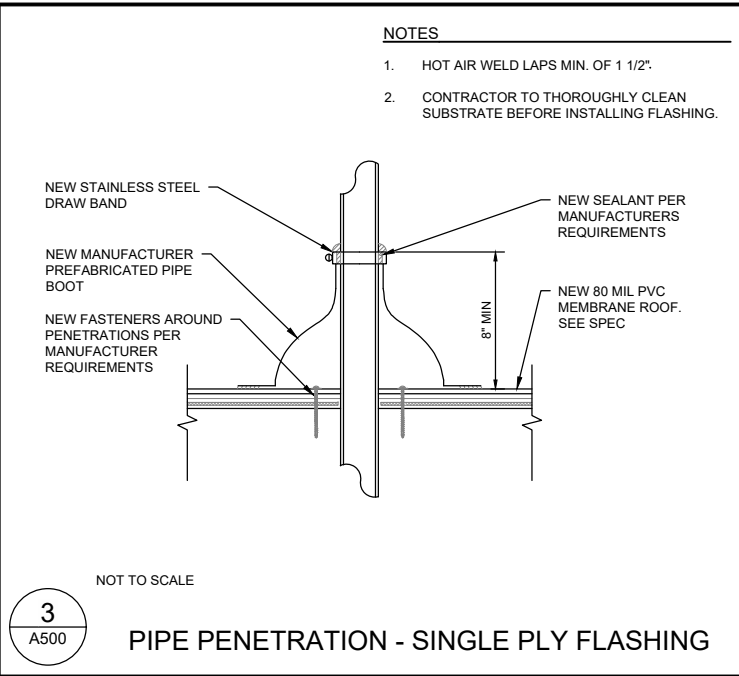

3 A500 PIPE PENETRATION - SINGLE PLY FLASHING

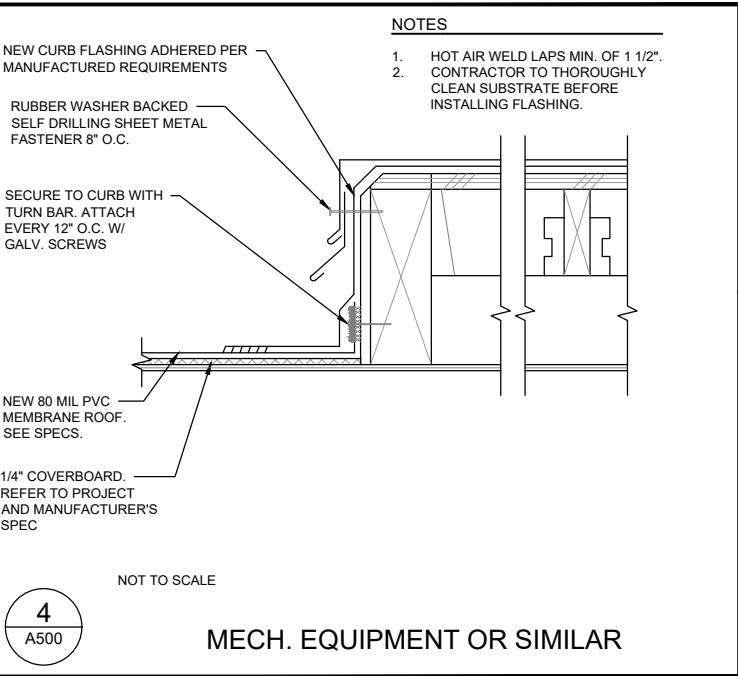

4 A500 MECH. EQUIPMENT OR SIMILAR

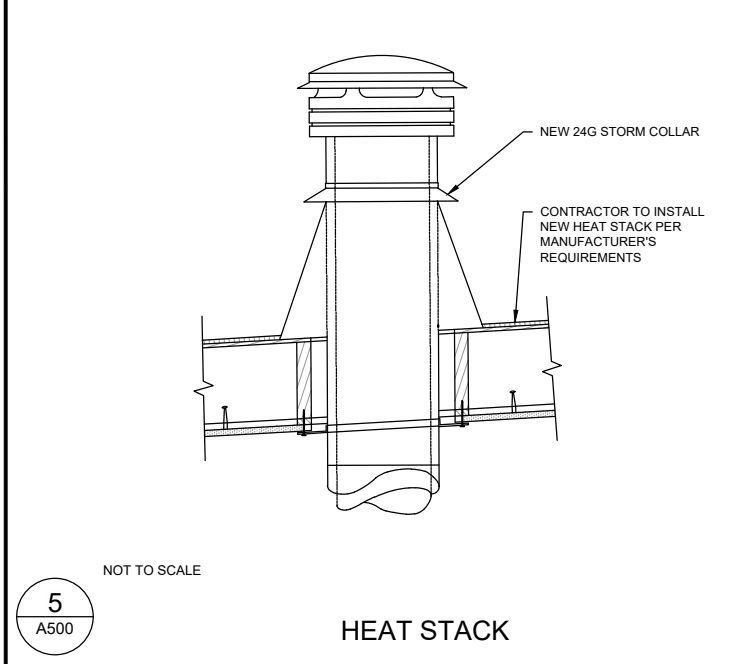

5 A500 HEAT STACK

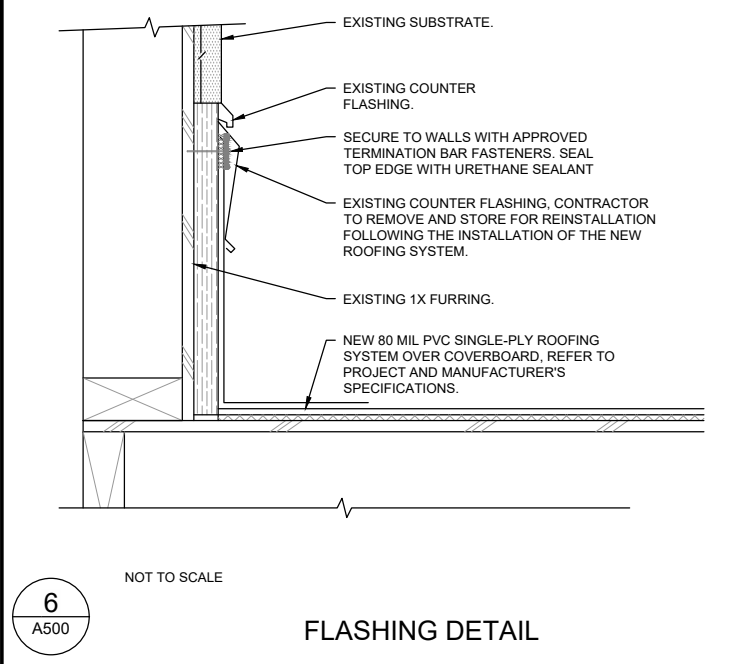

6 A500 FLASHING DETAIL

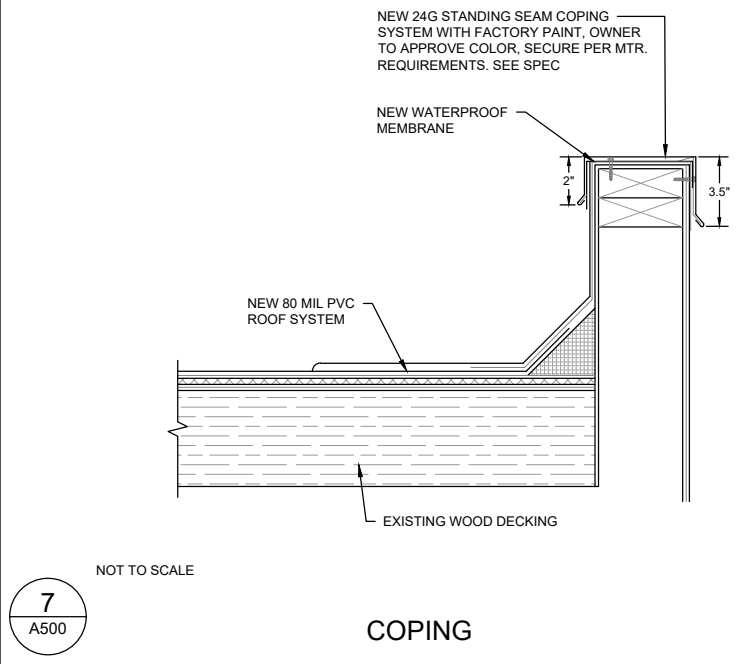

7 A500 COPING

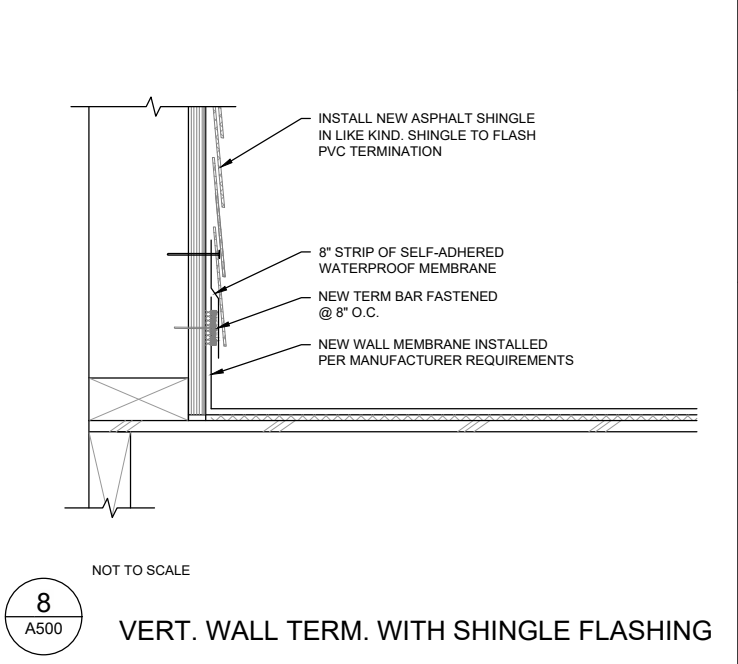

8 A500 VERT. WALL TERM. WITH SHINGLE FLASHING

COPYRIGHT 2004 BY PROVOST & PRITCHARD ENGINEERING GROUP, INC. ALL RIGHTS RESERVED. The firm of Provoost & Pritchard Engineering Group, Inc. expressly disclaims any and all liability for the use of the drawings, specifications or copies in any form or manner whatsoever, nor are they to be held responsible for any errors or omissions in the drawings, specifications or copies in these plans. These plans are not to be reproduced, changed or altered in any way without the written consent of Provoost & Pritchard Engineering Group, Inc. In the event of unauthorized reuse of these plans by a third party, the firm of Provoost & Pritchard Engineering Group, Inc. shall be held liable for any and all damages, including reasonable attorneys' fees, incurred by Provoost & Pritchard Engineering Group, Inc. legal fees associated with defending and enforcing these rights.

FOR CONSTRUCTION 4-5-24

REEROOF OF LIBERTY ELEMENTARY SCHOOL MULTIPURPOSE ROOM AND SNACK BAR CLOVIS UNIFIED SCHOOL DISTRICT FRESNO COUNTY ARCHITECTURAL

CONSTRUCTION DETAILS

PROVOST & PRITCHARD ARCHITECTURAL GROUP, INC. CLOVIS, CA 93311-1366 PHONE (559) 448-2700 FAX (559) 448-2715 www.provoostandpritchard.com

DESIGN ENGINEER: TROY BROOKS
 DRAFTED BY: IR CHECKED BY: SB
 DATE: 4-5-24
 JOB NO: 1087-24001
 PROJECT NO: 1087-24001
 PHASE: ROOF
 ORIGINAL SCALE SHOWN IS ONE INCH. ADJUST SCALE FOR REDUCED OR ENLARGED PLANS.
 SHEET A500
 4 OF 4

4/4/2024 3:51 PM g:\obovis\ascl-1087\108724001\reeroof of liberty elem\300 CAD\340 sheet sets\02_Architectural\A500 CONSTRUCTION DETAILS.dwg -Greg Feaver



EMSL Analytical, Inc.

3356 West Catalina Drive Phoenix, AZ 85017

Tel/Fax: (602) 276-4344 / (602) 276-4053

<http://www.EMSL.com> / phoenixlab@emsl.com

EMSL Order: 122401746
Customer ID: BROK78
Customer PO:
Project ID:

Attention: Lab Reports Provost & Pritchard Consulting Group 455 West Fir Avenue Clovis, CA 93611	Phone: (559) 298-9135 Fax: (559) 298-2281 Received Date: 03/14/2024 9:30 AM Analysis Date: 03/14/2024 Collected Date: 03/13/2024
Project: Liberty Elementary / 1250 E. Liberty Hill	

**Test Report: Asbestos Analysis of Bulk Materials via AHERA Method 40CFR 763 Subpart E
Appendix E supplemented with EPA 600/R-93/116 using Polarized Light Microscopy**

Sample	Description	Appearance	Non-Asbestos		Asbestos
			% Fibrous	% Non-Fibrous	% Type
12-01-Roofing <small>122401746-0001</small>	Built-Up Roof System	Black Fibrous Homogeneous	10% Glass	90% Non-fibrous (Other)	None Detected
12-01-Insulation <small>122401746-0001A</small>	Built-Up Roof System	Tan Fibrous Homogeneous	99% Cellulose	1% Non-fibrous (Other)	None Detected

Analyst(s) _____
Nathan Stancik (2)

Erica Furphy, PLM Supervisor
or Other Approved Signatory

EMSL maintains liability limited to cost of analysis. Interpretation and use of test results are the responsibility of the client. This report relates only to the samples reported above, and may not be reproduced, except in full, without written approval by EMSL. EMSL bears no responsibility for sample collection activities or analytical method limitations. The report reflects the samples as received. Results are generated from the field sampling data (sampling volumes and areas, locations, etc.) provided by the client on the Chain of Custody. Samples are within quality control criteria and met method specifications unless otherwise noted. The above analyses were performed in general compliance with Appendix E to Subpart E of 40 CFR (previously EPA 600/M4-82-020 "Interim Method") but augmented with procedures outlined in the 1993 ("final") version of the method. This report must not be used by the client to claim product certification, approval, or endorsement by NVLAP, NIST or any agency of the federal government. Non-friable organically bound materials present a problem matrix and therefore EMSL recommends gravimetric reduction prior to analysis. Unless requested by the client, building materials manufactured with multiple layers (i.e. linoleum, wallboard, etc.) are reported as a single sample. Estimation of uncertainty is available on request.

Samples analyzed by EMSL Analytical, Inc. Phoenix, AZ NVLAP Lab Code 200811-0, AZ0937, CO AL-19027, CA 2761, TX 300484, HI L-14-004, LA 05113

Initial report from: 03/15/2024 10:03:49

122401746

TURN-AROUND TIME

6 HRS. 24HRS. 48HRS. 72HRS. 10 Days

EMAIL RESULTS TO: Lab@ppeng.com

BILL TO:

PAGE 1 OF 1 SAMPLING DATA & CHAIN OF CUSTODY
DATE 3-13-24 TESTING LAB: FMSL

PROJECT INFORMATION

PROJECT NAME: LIBERTY ELEMENTARY
ADDRESS: 1250 E. LIBERTY HILL
PROJECT #
CONTACT: TROY B. 287-8357 TIM T. 284-5573 GREG F. 360-3694
MOBIL # (559)

CLIENT: Clovis USD
ANALYSIS: PLM STANDARD LEAD PAINT

D = Drywall, TM = Taping Mud, T = Texture, CB&A = Cove Base Adhesive
VFT = Vinyl Floor Tile, VSF = Vinyl Sheet Flooring, CM = Carpet Mastic,
CT = Ceiling Tile, ACS = Spray-on Acoustical Ceiling Material.

SAMPLE #	SAMPLE DESCRIPTION	SAMPLE LOCATION	W-Wall		Condition (Good, Fair, Poor)	S-Surfacing		F - Friable NF - Non Friable	Quantity
			C-Ceiling	F-Floor		T-Thermal	M-Misc.		

12-01 Bolt-up Reef System Low-Slope Roof

TRANSACTIONS

TRANSACTIONS

SHIPPING PAID BY :

REINQUISHED BY SIGNATURE: *[Signature]* DATE: 3-13-24 APPROVED BY SIGNATURE: *[Signature]* DATE: 3/14/23

REINQUISHED BY SIGNATURE: *[Signature]* DATE: APPROVED BY SIGNATURE: DATE:

LAB CLIENT BROOKS

T. Brooks & Associates, A Division of Provost & Pritchard Consulting Group
455 W. Fir Ave., Fresno, CA 93611 (559) 449-2700

Phone: 2967 7136 8723